

Fire Rated Enclosure Installation Technique and Design Advisory Manual

Pyroscat® Duct Wrap XL



DryerWrap



FastDoor™ XL



PlenumWrap®+

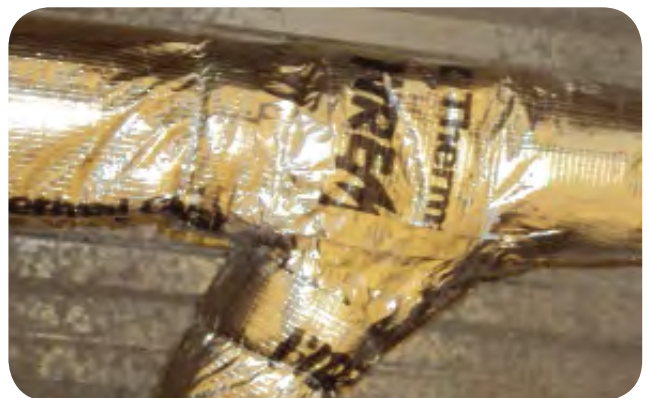

Table of Contents

Specification and Installation Instructions	
• Pyroscat® Duct Wrap XL	3
• FastDoor™ XL	7
• DryerWrap	8
• PlenumWrap®+	10
FireMaster and Pyroscat Equivalency Letter	12
Supplemental Drawings and Instructions	
• 1 or 2 Hour Shaft Alternative/Zero Clearance to Combustibles (XL001)	13
• Through Penetration System (XL003)	14
• FastDoor XL Installation Drawing (XL038)	15
• DuctMate; CHG; and Field Fabricated Access Doors (XL002)	16
• Steel Pin Layout for Duct Spans > 24" Wide to Prevent Blanket Sag (XL004)	17
• 2 and 3 Sided Wrap Detail for Attaching to Walls and/or Ceilings (XL005)	18
• Wrapping Detail for Vertical Duct with Angle Supports (XL007)	19
• Grease Duct Exiting Roof (XL011)	20
• Incorporating Sprinkler Lines into Grease Duct Systems (XL012)	21
• Installation for Pipe, Conduit, or Support Hanger Penetration of Wrap (XL014)	22
• Installation Detail for Transition to Rated Vertical Shaft (XL009)	23
• Installation Detail for Transition to Rated Horizontal Shaft (XL015)	24
• Installation Detail for Grease Hoods (XL022)	25
Optimized Grease Duct Enclosure System	26
Installation Pictures, good installations and bad access door examples	27
UL Listings (Go to www.ul.com for complete certifications directory)	
• HNKT G18 – 2 Hour / Zero Clearance Grease Duct Listing per ASTM E 2336	30
• C-AJ-7021 – Concrete Floor/Wall penetration for grease duct, wrap terminated	32
• C-AJ-7098 – Concrete Floor/Wall penetration for grease duct, wrap continuous	33
• F-C-7036 – Wood/Gypsum Floor penetration for grease duct	34
• W-L-7121 – Gypsum Wall penetration for grease duct, wrap continuous	36
• HNLJ V19 – 2 Hour Ventilation Duct Listing	38
• HNLJ V2 – 3 Hour Ventilation Duct Listing	40
• HNLJ V29 – 1 Hour Dryer Duct Listing for 4" diameter 30 Gage Duct	42
• C-AJ-7019 – Concrete Floor/Wall penetration for HVAC duct, wrap terminated	43
• C-AJ-7095 – Concrete Floor/Wall penetration for HVAC duct, wrap continuous	44
• W-J-7086 – Concrete Wall penetration / Max 100"x100" duct	45
• W-L-7145 - Gypsum Wall thru penetration / Max 100" ducts / STI Sealants	46
ICC-ES Approvals / Additional Resources / Notes	48



* Commonly referred to test method CA Section 01350 is CDPH Standard Method for the Testing and Evaluation of Volatile Organic Chemical Emissions from Indoor Sources Using Environmental Chambers Version 1.1, Feb 2010

Grease Duct Enclosure System Air Ventilation Duct Enclosure System

Product Data & Installation Guide

1. Product Description

Thermal Ceramics Pyroscat® Duct Wrap XL is a flexible blanket composed of high temperature fibers classified for applications to 2192°F (1200°C) and fully encapsulated in a durable glass fiber reinforced foil facing for easy handling and installation. Pyroscat Duct Wrap XL is UL and ULC Listed for 1 and 2 hour fire resistive enclosure protection, zero clearance for kitchen exhaust ducts, electrical circuit protection, and as a component in UL firestop designs for fire resistance rated floors, ceilings, and walls. The core fibers in Pyroscat Duct Wrap XL are manufactured using Thermal Ceramics patented Superwool® fiber which is an alkaline-earth silicate wool with low biopersistence and therefore increased safety for installers. Pyroscat Duct Wrap XL is under UL's Follow-Up Service Program to ensure the consistent quality essential to this life-safety application.

Product Features

- Thin and Lightweight at 1-1/2" (38mm) thick, 6 pcf (96 kg/m³) density
- Contours easily to complex duct designs
- Grease duct installation UL and ULC Listed with butt joints at all seams on both layers
- Fully foil encapsulated for fast and clean installation
- Contains 2192°F (1200°C) rated fibers
- Microbial Resistance validated by UL Environment
- Good sound absorption
- Compliant to IMC, NFPA 96, UMC, CMC, CNBC

2. Applications

- 2 hour enclosure and firestop system for kitchen exhaust duct
- Zero clearance to combustibles
- 1, 2 and 3 hour enclosure and firestop system for hazardous exhaust ducts, pressurization ducts, clothes dryer exhaust ducts, trash and linen chutes, and other fire rated HVAC ducts
- 1 hour electrical circuit integrity protection
- Engineered and tested solutions for fire protection of structural steel and storage vessels per ASTM E119, ISO 834, and UL1709

3. Specifications - Division 23 07 00 (or 15080)

CSI Spec and AutoCAD available online, www.arcad.com/sd/clients/thermcer.html.

Thermal Ceramics Pyroscat Duct Wrap XL is a flexible high temperature insulation rated to 2192°F (1200°C) that is fully encapsulated in FSP facing. The duct enclosure system shall be listed by UL and /or ULC per ASTM E 2336, CAN/ULC S144 and ISO 6944 for 1-, 2- and 3-hour rating and zero clearance to combustibles, and tested per ASTM E84 for a flame/smoke rating less than 25/50. Insulation shall have a nominal thickness of 1-1/2 inches (38 mm) and density of 6 lbs/ft³ (96 kg/m³). Insulation shall have a R-Value of 7.3 at 75°F. Installation shall be in strict accordance to manufacturers published installation instructions, UL or ULC Listings, and shop drawings. FastDoor™ XL shall be used for duct access where specified or as required by code.

4. Physical Characteristics

Product	Unit	Size	Units/ Ctn.	Wt./ Ctn.
Pyroscat Duct Wrap XL	Roll	1-1/2" x 24" x 25'	1	37.5 lbs.
Pyroscat Duct Wrap XL	Roll	1-1/2" x 48" x 25'	1	75 lbs.

5. Performance Specifications

Reference Standard	Standard No.	Performance
Grease Duct Enclosure System	ASTM E2336	Pass
Section 16.1 - Non-Combustibility	ASTM E136	Pass
Section 16.2-Fire Resistance (wall)	ASTM E119	Pass
Section 16.3 - Durability Test	ASTM C518	Pass
Section 16.4 - Internal Fire Test	ASTM E2336	Pass
Section 16.5 - Fire Engulfment (duct)	ASTM E814/ E119	Pass
ULC Grease Duct Test Protocol		Pass
Standard Methods of Fire Resistance Tests - Grease Duct Assemblies	CAN/ULC S144	Pass
Grease Duct Clearances	UL 1978	Pass
Air Ventilation Duct Enclosure	ISO 6944	Pass
Surface Burning Characteristics	ASTM E84	<25/50
Thermal Resistance (R-value @ 75°F)	ASTM C518	7.3 per layer
Mold Growth	ASTM C1338	ULE Validated
Low VOCs	CA Standard 01350	ULE Validated

6. Listings/Building Code Reports

Listed Uses	Agency	Listing	Layers
Grease Duct Enclosure per ASTM E2336 and AC101 (2006, 2009, 2012 IMC, NFPA 96, UMC, CMC)	UL	G18	2
	ICC-ES	ESR 2213	
ULC Grease Duct Test Protocol and CAN/ULC S144*	ULC	FRD 4, 7*	2
Grease Duct Insulation (2003 IMC)	OPL	TC/BI 120-01	1
Through Penetration FireStop System per ASTM E814, UL 1479	UL	See Figure 2	1 or 2
	ULC		
1- or 2-hour Ventilation Duct Enclosure per ISO 6944-1985	UL	HNLJ.V1, 19, 29	1
	ULC	FRD 3, 5, 6, 18	
3-hour Ventilation Duct Enclosure per ISO 6944-1985	UL	HNLJ.V2	2
Electrical Circuit Protective System	UL	FHIT.5	2

7. Storage

Thermal Ceramics Pyroscat Duct Wrap XL must be stored in a dry warehouse environment on pallets. Pallets should not be stacked.

8. Installation

Thermal Ceramics Pyroscat Duct Wrap XL shall be installed by a qualified contractor in accordance with manufacturer's instructions and laboratory design listings.

Materials and Equipment

- Thermal Ceramics Pyroscat Duct Wrap XL blanket
- Aluminum foil tape
- Glass filament reinforced tape (optional)
- Carbon steel or stainless steel banding material, minimum 1/2" (13mm) wide, minimum 0.015" (0.4mm) thick, with steel banding clips
- Hand banding tensioner and crimping tool
- Minimum 12 gage (3mm) steel insulation pins; steel speed clips, minimum 1-1/2" (38mm) square or 1-1/2" (38mm) diameter, or equivalent sized cup-head pins;
- Capacitor discharge stud gun
- Thermal Ceramics FastDoor™ XL
- An approved firestop sealant

General

Cut edges of the blanket shall be taped with aluminum foil tape to prevent exposed edges of the insulation absorbing grease and moisture in the event of a compromised grease duct joint or condensation. Overlaps and/or tightly butted joints are used to block heat transfer in the event of duct deformation resulting from thermal expansion. Filament tape is suggested to hold the blanket in place until steel banding or pinning is installed to permanently secure the blanket.

A. Installation on Grease Duct per ASTM E2336 and CAN/ULC S144 (Figure 1)

System requires two layers of insulation applied directly to the duct with tight butt joints at all seams on both layers. The first layer of insulation is cut to a length sufficient to wrap around the duct and provide a tight butt joint where the blanket ends meet. Adjacent blankets on the first layer are butted tightly together with longitudinal seams offset minimum 6" (150mm). The second layer of insulation is installed in the same method as the first layer, with seams between layers offset a minimum of 6" (150mm). Banding and/or pinning per Section D is used to permanently secure the insulation to the duct.

B. Installation on HVAC Duct per ISO 6944 (Figure 1)

System requires one layer of insulation applied directly to the duct with 3" (75mm) overlaps at all seams. The insulation is cut to a length sufficient to wrap around the duct and provide a 3" (75mm) overlap where the blanket ends meet. Adjacent blankets are installed to provide a minimum overlap of 3" (75mm). Banding and/or pinning per Section D is used to permanently secure the insulation to the duct.

C. 2 & 3 Sided Wrap Installation (Figure 4)

When space does not allow for a complete wrap applied to the duct on all four sides, the Pyroscat Duct Wrap XL is approved for 2 or 3 sided installations with mechanical attachment to a rated concrete or CMU assembly. (See Figure 4 for installation details.)

D. Mechanical Attachment Methods

- 1) Banding (Figure 1)** - Minimum 1/2" (13mm) wide carbon steel or stainless steel banding, 0.015" (0.4mm) thick, is placed around the entire perimeter of the insulated duct on maximum 10-1/2" (270mm) centers and 1-1/2" (38mm) from each blanket edge or 1-1/2" (38mm) from each collar edge when using the butt joint and collar method. The banding is placed around the blanket and tightened to firmly hold the Pyroscat Duct Wrap XL in place against the duct, but not cause any cutting or damage to the blanket.
- 2) Pinning** - Pinning on all sides of the duct may be used as an alternative to banding. For ducts wider than 24" (610mm) pinning is required on the bottom of horizontal runs, or on one side of vertical runs (in addition to steel banding). When applicable, 12 Gage (0.4mm) steel pins are installed on 12"

(305mm) centers along the width of the duct and 10-1/2" (270mm) centers along the length of the duct. Pins that extend beyond the outer blanket layer shall be turned down or the excessive length cut off to prevent sharp edges. Shoot through pins (cup head pins) may be used in conjunction with steel banding to prevent blanket sag.

E. Access Doors

- 1) FastDoor™ XL (Figure 3)** - FastDoor XL is a UL Listed, liquid tight duct cover panel supplied complete with a single layer insulation cover per UL Listing HNKT G18. The FastDoor XL is installed per included installation instructions. No field welding is required.

- 2) Field Fabricated Access Doors** - Each access door assembly has four threaded rods 1/4 inch (6mm) in diameter and 5" (127mm) in length, with one welded to each corner of the door opening. Hollow steel tubes, 4-1/2" (114mm) long are installed outside the access cover plate and over the threaded rods. Four 12 gage (3mm) and 4-1/2" (114mm) long steel insulation pins are welded to the access cover plate to allow for installation of the three layers of Pyroscat Duct Wrap XL. One layer of Pyroscat Duct Wrap XL is cut to approximately the same size as the access panel, and impaled over the insulation pins on the panel. A second layer of Pyroscat Duct Wrap XL is cut so as to overlap the first layer a minimum of 1-1/2" (38mm). It is essential that the first and second layer fit tightly against the surrounding wrap with no through openings. The third and outside layer should be cut to overlap the second insulation layer by a minimum of 1-1/2" (38mm). Minimum 1-1/2" (38mm) round or square insulation clips are installed on the insulation pins to secure the three layers of insulation to the access cover plate. All cut edges of the insulation shall be taped with minimum 3" (75mm) wide aluminum foil tape. Wing nuts and washers are installed on the four threaded rods, and tightened against the hollow steel tubes to seal the access cover plate to the duct.

- F. Through Penetration Firestop System (Figure 2)** - When the duct penetrates a fire rated assembly an approved fire stop system must be employed. Figure 2 provides a complete list of

UL / ULC firestop design listings which can be found in the Certifications Directory at www.ul.com for US systems and www.ulc.ca for Canadian systems. Prior to installing any firestop system the surfaces of all openings and penetrating items must be clean and dry. The Pyroscat Duct Wrap XL core blanket (or mineral wool where allowed by the firestop design listing) must be compressed into the annular space. The packing material must be recessed a minimum depth from the surface of the concrete or gypsum assembly. The recessed opening must be filled with a minimum thickness of an approved firestop sealant. The packing material type and compression, minimum recess (typically 1/4" (6mm)), and

approved firestop sealant and thickness (typically 1/4" (6mm)) shall be as specified in an approved UL / ULC firestop design listing. When there is not sufficient annular space around the duct to run the Pyroscat Duct Wrap XL enclosure system continuous through the fire rated assembly, the enclosure may terminate above and below the floor/ceiling assembly or on either side of a wall assembly as shown in Figure 2. When this method is used, the Pyroscat Duct Wrap XL must be mechanically attached on either side of the fire rated assembly using one of the attachment methods described in Section D, spaced a maximum of 1-1/2" (38mm) from the fire rated assembly.

G. Support Hanger Systems

1) Grease ducts: Trapeze support hangers shall be spaced on maximum 60 in. (1500 mm) centers. Hanger rods or straps shall be anchored with steel drop in or wedge expansion type masonry anchors. No additional protection is required for hangers and supports meeting the requirements of the Table below.

Hanger Cross Section	Maximum Perimeter, in (mm)	Trapeze Support (or equivalent Yield Strength), in (mm)
3/8 in (10 mm) threaded rod	148 (3759)	2 (51) x 2 (51) x 1/8 (3) in angle

2) HVAC ducts: Trapeze support hangers shall be spaced on maximum 60 in. (1500 mm) centers. Hanger rods or straps shall be anchored with steel drop in or wedge expansion type masonry anchors. No additional protection is required for hangers and supports meeting the requirements of the Table below.

Hanger Cross Section	Max. Perimeter, in (mm)	Trapeze Support (or equivalent Yield Strength), in (mm)
1 in x 1/6 gage strap (25 mm x 1.5 gage strap)	100 (2540)	
1/4 in (6 mm) threaded rod	50 (1270)	1 1/2 (38) x 1 1/2 (38) x 3/16 (5) angle
3/8 in (10 mm) threaded rod	150 (3810)	1 1/2 (38) x 1 1/2 (38) x 3/16 (5) angle
1/2 in (12.7 mm) threaded rod	218 (5540)	2 (51) x 2 (51) x 1/4 (6) angle

9. Maintenance and Repair

No maintenance is required when installed in accordance with Thermal Ceramics (TC) installation instructions. If damage is limited to the foil facing, aluminum foil tape can be used to repair the foil facing. If an area of blanket is found to be damaged the following procedure must be incorporated. If the damaged area is larger than 8" (203mm) x 8" (203mm) the entire wrap section must be removed and replaced according to TC installation instructions. If the damaged area is small (less than 8" (203mm) x 8" (203mm)), the damaged area must be cut away and replaced with a new section 1" (25mm) larger in length and width than the cut out, such that the new section can be compressed tightly into the cut out area. All cut edges of the new section must be taped and sealed with aluminum foil tape. The new section must be held in place with either pinning or banding per TC installation instructions.

10. Limitations

Thermal Ceramics Pyroscat Duct Wrap XL shall be installed in accordance with these installation instructions and appropriate laboratory design listings. The integrity of Pyroscat Duct Wrap XL systems is limited to the quality of the installation.

* For personal protective equipment recommendations, please see SDS.

Thermal Ceramics and Pyroscat are trademarks of Morgan Advanced Materials. Pyroscat products are manufactured by Thermal Ceramics and are distributed by authorized distributors.



FastDoor® XL



1. Product Description

Thermal Ceramics offers another innovation to our fire rated enclosure line, the FastDoor duct access system. The FastDoor system is comprised of a UL1978 tested and listed duct access door and an ASTM E2336 tested and listed enclosure cover plate. The duct access door is tested to be grease and fire tight when immersed in a simulated grease pan fire per UL1978. The access door is Union made and under UL follow-up inspection to ensure the finest quality. An included and ready to install insulated cover plate is compatible with FireMaster FastWrap XL and Pyroscat Duct Wrap XL installation on grease or air ducts, and is the only single layer door enclosure system available. This single layer of insulation is only 1-1/2 inches thick and provides zero clearance to adjacent combustibles and 2-hour rating per the stringent ASTM E2336 grease duct enclosure standard. The FastDoor system provides for fast and simple installation surpassing the requirements of NFPA 96 and the International Mechanical Code.

Product Features

- UL 1978 tested duct access door
- ASTM E2336 and ASTM E814 tested complete assembly
- Liquid tight gasket
- 1500°F high temperature gasket
- Zero clearance and 2-hour enclosure rating
- Underwriters Laboratory Listed
- Union fabricated sheet metal components
- Single layer, 1-1/2" thick enclosure insulation
- Code compliant signage included

Product Benefits

- Installed quickly utilizing included template
- Eliminates liability of "field fabricated" access doors
- Quality can be "specified" and controlled from the factory
- Passes jobsite inspections
- Reliable and safe entry over the life of the duct

2. Available Sizes

10" x 6" for hand access to rectangular ducts
 12" x 8" for hand access to rectangular ducts
 12" x 12" for shoulder access to rectangular ducts
 16" x 12" for shoulder access to rectangular ducts
 20" x 20" for full access to rectangular ducts
 Special Order available for round duct doors, and Stainless Steel option

3. Performance Specifications

Test Standard	UL / ULC Listings
ASTM E2336	HNKT.G-18 / FRD 4
UL 1978	YYXS.MH47995

4. Specifications – Division 23 33 33 (or 15280)

CSI Spec and AutoCAD available online,
www.arcat.com/sd/clients/thermcer.html

Thermal Ceramics FastDoor XL shall be installed for grease duct access at each change in direction and at intervals as required by code and acceptable to the building official. FastDoor XL is a factory built grease duct access door system providing zero clearance and 2-hour fire rating with UL Listings per ASTM E2336 (HNKT G18) and UL1978 (YYXS.MH47995). FastDoor XL is installed fire tight with NFPA 96 compliant high temperature gasket and liquid tight with integral closed cell neoprene gasket. Installation shall be performed by an experienced contractor per manufacturer instructions and applicable UL Listings. Sheet metal and insulation contractors shall coordinate installation of the FastDoor XL and the duct enclosure system.

5. Installation

Materials and Equipment:

- FastDoor complete with duct door, insulated cover, cut-out templates, and installation hardware
- Reciprocating saw, snippers, or torch to cut access hole in duct
- Drill and 3/8" bit
- Insulation knife
- 4" Aluminum foil tape

Installation of the duct access door: Peel off and place the duct door cut-out template in the desired location. Retain the remainder of the template as a guide to cut the enclosure insulation. Drill 3/8" holes at the marked locations. Cut the access hole along the provided cut-out line. Install retaining clips at each 3/8" hole, ensuring that the nut is centered in the hole. Locate the duct access door over the access opening, aligning the holes and the retaining clips. Loosely install all the wing nuts, using the extension nuts with threaded rods on the four corners. Finger tighten each fastener until snug.

Installation of the enclosure cover: The duct should be insulated according to Thermal Ceramics installation instructions. Center the retained insulation cut-out template over the duct access door, using the two threaded rods protruding through the insulated duct as a guide. Cut through the enclosure insulation all the way to the bare duct. Seal the cut insulation using 4" wide aluminum foil tape. Install the enclosure cover plate over the two threaded rods. Adjust the duct insulation as necessary to allow for a tight overlap and no gaps between the duct insulation and the enclosure cover. Install and finger tighten the provided washers and wing nuts.



FireMaster DryerWrap

1. Product Description

Thermal Ceramics newest fire rated duct wrap product is FireMaster DryerWrap for application on dryer vent ductwork in multi-unit housing where fire compartmentation and life safety are major concerns. FireMaster DryerWrap is tested and UL Listed for 1-hour fire resistance on light gage construction up to 7 inch diameter or 10x4 inch rectangular duct penetrating 1-hour rated wood joist gypsum floor therefore providing Owners, Architects, and Engineers a viable and cost effective solution for safely routing dryer exhausts from the laundry room to the exit of the building. At 1 inch thick and 6 pound per cubic foot density, FireMaster DryerWrap is 50% thinner, lighter, and appreciably more flexible than any other alternative fire wraps currently available. The optimized thickness and approved 1 inch compression or overlap joints provide for significant installation cost and space savings.

Product Features

- 1 inch thick, 6 lb per cubic foot density
- High temperature insulation rated for 2100°F continuous exposure
- Underwriters Laboratory tested and Listed per ISO6944 and ASTM E814 (UL1479)
- Fully Encapsulated in scrim reinforced foil facing
- 1 inch compression or overlap at joints allows for installation inside 6 inch space
- Installation using 16 gage galvanized steel tie-wire
- Tested on 30 gage 4 inch duct and 26 gage, typical of dryer and domestic kitchen range vent construction

Product Benefits

- Optimized installation cost
- Optimized installation space
- Easily to cut
- More flexible than alternative wraps
- Improved safety with application specific testing

2. Physical Characteristics

Length x Width:	300 inches x 20 or 48 inches
Thickness:	1 inch
Density:	6 lb. per cubic foot
Encapsulation:	Scrim reinforced foil (FSP)
Packaging:	1 roll per carton
Blanket Weight:	21 lbs for 20 inch width, 50 lbs for 48 inch width

3. Performance Specification

ISO 6944	1-Hour Rating
ASTM E814 (UL1479)	1-Hour T-Rating
ASTM E814 (UL1479)	1-Hour F-Rating
ASTM E84 -Flame Spread	< 25
ASTM E84 -Smoke Developed	< 50
ASTM E136	Pass
ASTM C518 -R-Value at 70°F	4.9
ASTM D6329 (Mold at 75 R.H.)	Resistant

4. Codes Compliance and Laboratory Listings

2009 IBC Sections 716.6.2, 708, and 703
 2009 IMC Section 504.2 and 604
 UL Listing F-C-7055 for 1-Hour F-and T-Rating
 UL Listing HNLJ.V-29 for 1-Hour Ventilation Duct Rating
 ULC Listing FRD 28 for 1-Hour Ventilation Duct Rating

5. Installation

Materials and Equipment

- FireMaster DryerWrap
- 3" Tape (UL 181 Listed and Labeled)
- Serrated knife recommend
- 16 Gage galvanized steel tie-wire
- Wire cutters

Installation: Cut insulation to the length of the duct to be wrapped, and tape seal cut edges using 3" foil tape. For 4" dryer ducts the as supplied 20" width will be sufficient to provide for either a 1" compression or 1" overlap on the longitudinal joint. This long joint may be tape sealed utilizing 3" foil tape at the contractors discretion. Adjacent blankets or ducts wrapped using 48" width blanket cut to a length sufficient to wrap around the duct are installed with either a minimum 1" compression or 1" overlap at the joint between blankets. Utilizing minimum 16 gage tie-wire, cut wire to sufficient length to wrap the insulated duct and make a small loop in one end. Wrap the tie-wire around the insulated duct on maximum 8" centers. Where the insulated duct passes through 1-hour rated floor/ceiling assemblies, the penetration should be framed out and the annular space packed with scrap FireMaster insulation recessed minimum 1/4 inch from top surface. The recesses space shall be filled with a UL Listed firestop sealant per F-C-7055.

DRYERWRAP FOR 1-HOUR ENCLOSURE OF DRYER VENTS

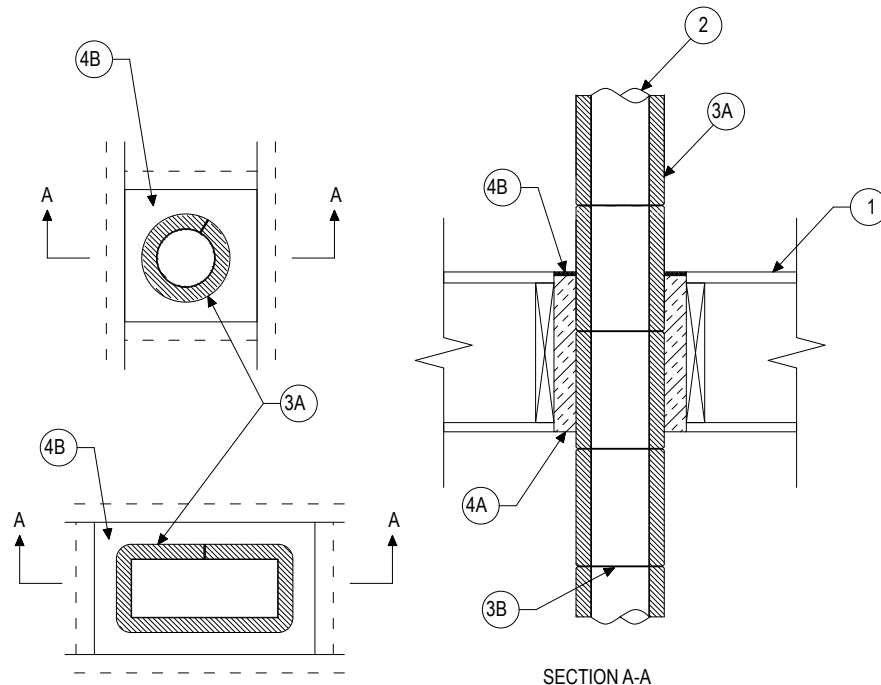

LEGEND	
1	1-Hour UL Listed Floor/Ceiling Assembly
2	Maximum 4" Diameter, 30 Gage or Maximum 7" Diameter or 10x4" Rect. 26 Gage Duct
3A	FireMaster DryerWrap with 1" longitudinal and transverse compression or overlap joints
3B	Minimum 16 Gage galvanized steel tie-wire installed on maximum 8" centers
4A	FireMaster blanket (foil removed) packed into annular space (25% min. compression)
4B	Firestop sealant per F-C-7055 (FireMaster Putty or approved alternative)

The integrity of FireMaster duct systems is limited to the quality of the installation.

UL Listings HNLJ.V-29
ULC Listings FRD 28
UL Listings F-C-7055

TESTED ASSEMBLY; EQUIVALENT TO 1-HR F AND T-RATING

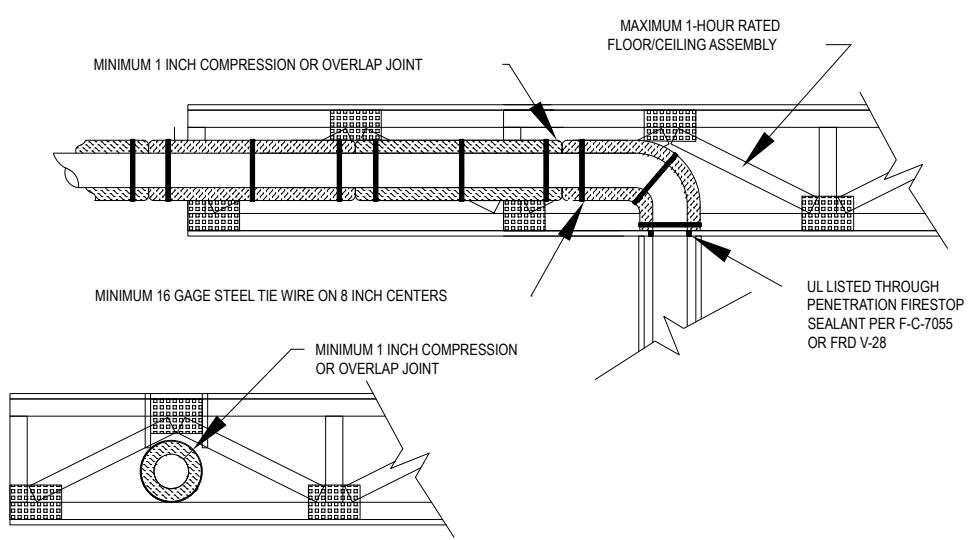



PlenumWrap®+ Plastic Pipe and Cable System

1. Product Description

Building Codes require that materials exposed within plenums shall have a flame spread index of not more than 25 and a smoke developed index of not more than 50. Many plastic pipes and plastic coatings on electrical cables do not meet these requirements. Thermal Ceramics PlenumWrap+ is a thin, lightweight, and flexible wrap material tested and laboratory listed to UL 1887, NFPA 262 (UL910), and ASTM E84 to reduce flame spread and smoke development of plastic pipe and plastic insulated copper cable installed in environmental air spaces (plenums). PlenumWrap+ core blanket is manufactured using Thermal Ceramics' patented Superwool fiber, a 2192°F rated, non-combustible, alkaline-earth silicate wool with low biopersistence. PlenumWrap+ is OPL (Intertek) Listed, and is part of both OPL's and UL's Listing and Follow-up Service Programs to ensure the consistent quality essential to the critical nature of this life-safety application.

Product Features

- Approved to reduce flame-spread (<25) and smoke development (<50) of plastic components in air plenums
- Thin and lightweight at 1/2 inch thick, 8 pcf density
- Contours easily to complex pipe and cable installations
- Fully foil encapsulated for fast and clean installation and to minimize dusting in return air plenums
- Easy to install using 1" overlaps and banding or wire ties to fasten
- Fill blanket is completely inorganic and non-combustible
- Contains 2192°F (1200°C) rated fibers for added security versus mineral wool or fiberglass fibers
- Resistant to mold growth at conditions of 75 -95 % relative humidity (ASTM D6329)
- Unaffected by oil or water
- Does not lose fire performance capabilities with age
- Available in 48 inch widths for less joints and installation labor

2. Applications

- PVC Pipes
- PVDF Pipes
- PE Pipes
- CPVC Pipes
- ABS Pipes
- Electrical Cables
- PP Pipes
- PB Pipes

3. Physical Characteristics

Duct Product	Unit	Size	Units/Ctn.	Wt./Ctn.
PlenumWrap+	Roll	1/2" x 24" x 50'	1	42 lbs.
PlenumWrap+	Roll	1/2" x 48" x 25'	2	89 lbs.
Color	White blanket with silver foil encapsulation			

4. Specifications/Listings

Application	Fire Resistive Rating	Enclosure System	Listing No.
Plastic Pipes	UL 1887	1 layer PlenumWrap+	OPL PP108 P UL R14229
Electric Cables	NFPA 262 (UL 910)	1 layer PlenumWrap+	OPL PP109 P UL R14229

5. Performance

UL 1887 NFPA 262 (UL 910)	Optical Smoke Density Peak	0.03
	Optical Smoke Density Average	0.01
	Flame Propagation (ft.)	2.6
ASTM E84	Flame Spread	15
	Smoke Developed	10

6. Specifications – Division 23 07 00 (or 15080)

CSI Spec and AutoCAD available online,
www.arcad.com/sd/clients/thermcer.html

Thermal Ceramics PlenumWrap+ is a low biopersistence fiber blanket rated to 2192F, and is listed by Intertek (OPL) as an enclosure system per ASTM E84, NFPA 252, and UL1881. Insulation is 1/2" thickness and 8# density.

Subject to Authority Having Jurisdiction approval, PlenumWrap+ shall be installed as an insulation jacketing over non-plenum rated plastic pipe and electrical jacketing (PVC and similar) to meet code requirements for maximum 25/50 rating per ASTM E84. Installation shall be performed by an experienced contractor per manufacturer instructions and applicable Intertek Listings.

7. Installation (Figure 1)

The PlenumWrap+ system shall be installed by a qualified contractor in accordance with the Thermal Ceramics manufacturer's instructions. Materials and Equipment:

- PlenumWrap+, 1/2" min. thickness, 24" wide by 50' long, and 48" wide by 25' long
- Glass filament reinforced tape (optional)
- Aluminum foil tape for sealing cut edges of foil encapsulated blanket
- Banding material, minimum 1/2" wide, 0.015" thick, carbon or stainless steel. Note: One strand of minimum 16 gauge carbon or stainless steel tie wire may be used as an alternative
- Hand tensioning tool and crimping tool

Installation Method:

- Cut PlenumWrap+ to a length sufficient to wrap completely around the perimeter of the pipe or cable, plus provide an overlap of not less than 1".
- Aluminum foil tape is used to seal cut edges of the encapsulated blanket during installation.
- Secure the PlenumWrap+ blanket in place by using glass filament tape as an optional temporary hold until banding or tie wire is in place.
- Cut the next adjacent wrap of PlenumWrap+ to completely wrap around the perimeter of the pipe or cable with enough excess to overlap itself not less than 1". A 1" longitudinal overlap is required onto the previous adjacent wrap.

- Banding - min. 1/2" wide, 0.015" thick carbon or stainless steel banding is placed around the entire perimeter of the insulated pipe or cable on maximum 11 1/2" centers, and 1/2" from each blanket edge. As an alternative, 16 gauge carbon or stainless steel tie wire may be used in place of banding. Tighten the banding or tie wire to hold the wrap firmly in place without cutting or damaging the wrap. Bands or tie wires may be hand tightened.

8. Storage:

PlenumWrap+ must be stored in a dry warehouse environment. Pallets should not be stacked.

9. Maintenance and Repair

No maintenance is required when installed in accordance with Thermal Ceramics installation instructions.

If damage is limited to the foil facing material, aluminum foil tape can be used to repair the foil facing.

If damage penetrates the foil facing and damages the underlying blanket, the entire section of blanket should be removed and replaced according to Thermal Ceramics installation instructions, ensuring the proper overlaps and mechanical fastening.

*For personal protective equipment recommendations see the SDS. Thermal Ceramics and PlenumWrap+ are trademarks of Morgan Advanced Materials. PlenumWrap+ products are manufactured by Thermal Ceramics and distributed through a network of authorized distributors.

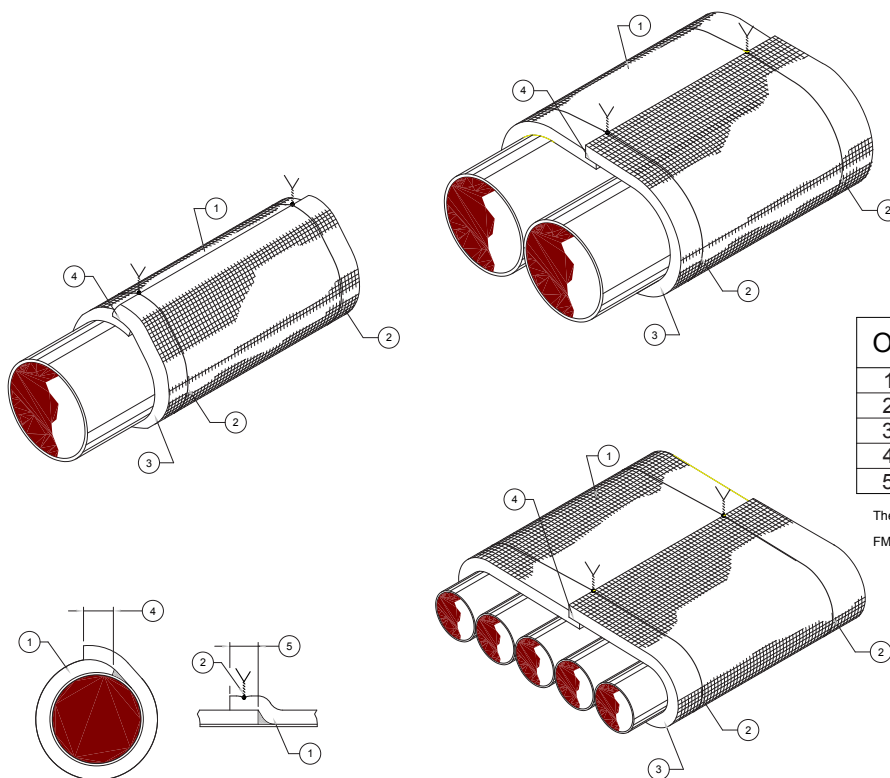

The integrity of Firemaster duct systems is limited to the quality of the installation.

FMPW001-0

Re: Equivalency of Thermal Ceramics FireMaster® FastWrap® XL and Pyroscat® Duct Wrap XL

This is to advise that both the Pyroscat and FireMaster brands of fire rated duct wrap are manufactured by the Thermal Ceramics business of Morgan Advanced Materials in our Augusta, GA facility. The FireMaster FastWrap XL and the Pyroscat Duct Wrap XL should be accepted as equivalents in all applications and installed in the same manner as described in the Thermal Ceramics installation manual. Both products may be installed on the same grease or HVAC duct. The two products have the properties shown in the following table:

Property	FireMaster FastWrap XL	Pyroscat DuctWrap XL
Manufacturing Location	Augusta, GA, USA	Augusta, GA, USA
Composition	High Temperature Low Biopersistence Fibers	High Temperature Low Biopersistence Fibers
Temperature Limit	Over 2192°F	Over 2192°F
Thickness	1-1/2"	1-1/2"
Density	6 pounds per cubic foot	6 pounds per cubic foot
Width	24" & 48" wide	24" & 48" wide
Length	25 ft. long	25 ft. long
R Value	7.3 per layer	7.3 per layer
Thermal Conductivity at 500°F	0.42 BTU•inch/Hr•Ft ² •°F	0.42 BTU•inch/Hr•Ft ² •°F
Thermal Conductivity at 1800°F	1.96 BTU•inch/Hr•Ft ² •°F	1.96 BTU•inch/Hr•Ft ² •°F
Area Weight	0.75 lbs per sq. ft.	0.75 lbs per sq. ft.
Fiber Fill Color	White	White
Foil Encapsulation	Fully Encapsulated, Purple Print	Fully Encapsulated, Black Print
Meets 2003 IMC	YES	YES
Flame spread & smoke developed (UL 723)	Blanket: 0 flame, 0 smoke	Blanket: 0 flame, 0 smoke
developed (UL 723)	Encapsulated: 5 flame, 5 smoke	Encapsulated: 5 flame, 5 smoke
UL Listing (Grease Duct per ASTM E2336)	HNKT G18	HNKT G18
OPL Listing (Grease Duct Clearance per UL 1978)	TC/BI 120-01	TC/BI 120-01
UL Listing (HVAC Duct)	HNLJ V19; V1; V2; V29	HNLJ V19; V1; V2; V29
ULC Fire Rated Duct Listings	FRD 3; 4; 5; 6; 7; 18; 28	FRD 3; 4; 5; 6; 7; 18; 28
ICC-ES Report	ESR 2213	ESR 2832

**Grease and HVAC Duct Enclosure System
1 or 2 Hour Shaft Alternative / Zero Clearance to Combustibles**

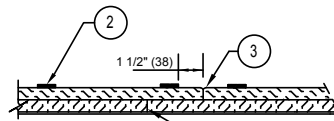
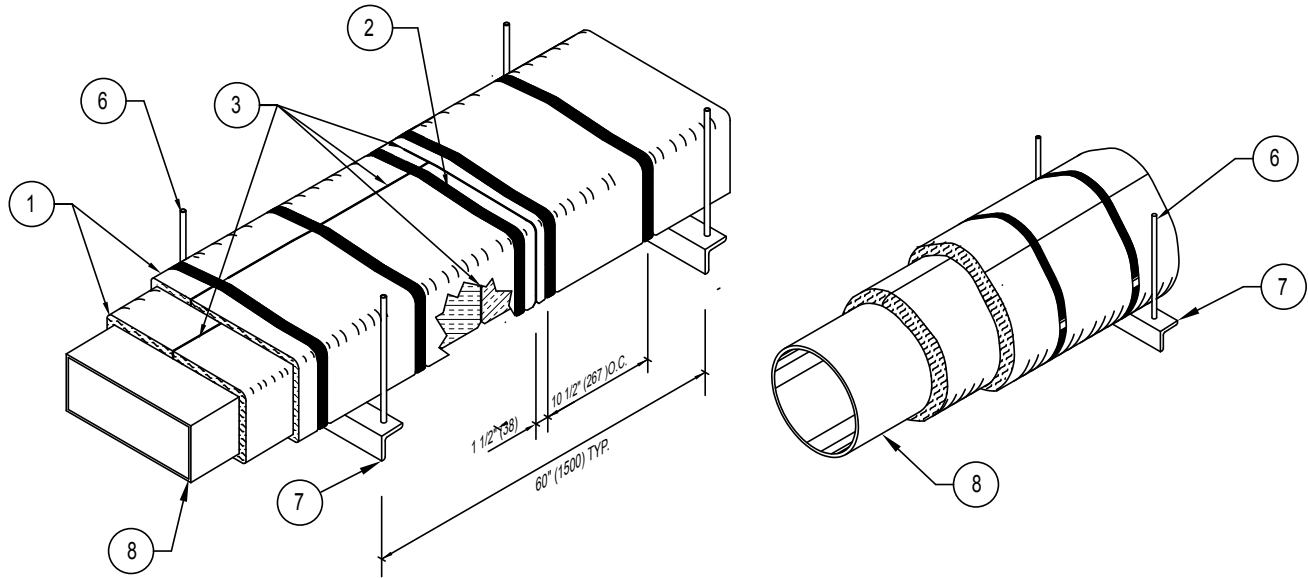

Butt Joint / Butt Joint Typical

TWO LAYER INSTALLATION (Grease Duct per ASTM E2336 and CAN/ULC S144)

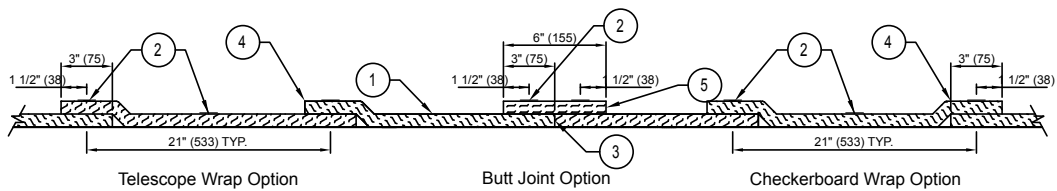

SINGLE LAYER INSTALLATION OPTIONS (2-Hour rated HVAC Duct per UL HNLJ V-19)

LEGEND	
1	Two Layers of XL Insulation for ASTM E2336 and CAN/ULC S144 Grease Duct Enclosures One Layer of XL Insulation for 2-Hour Air Ventilation Duct Enclosures
2	Steel banding minimum 1/2" (13) wide by 0.015" (0.4) thick.
3	Tight butt joints (no overlap) at perimeter and longitudinal joints, both layers for grease ducts
4	Min. 3" (75) overlap on perimeter and between adjacent blankets
5	Optional 6" XL collar
6	Hangers - size dependent weight of assembly (see datasheet Section G)
7	Trapeze Supports - size dependent on weight of assembly (see datasheet Section G)
8	Steel Rectangular or Round Duct (size, gage and construction dependent per Listed Design)

The integrity of Thermal Ceramics duct systems is limited to the quality of the installation.

XL001-10

**Commercial Kitchen Grease Duct Enclosure System
Air Ventilation Duct Enclosure System
Through Penetration Firestop Systems**

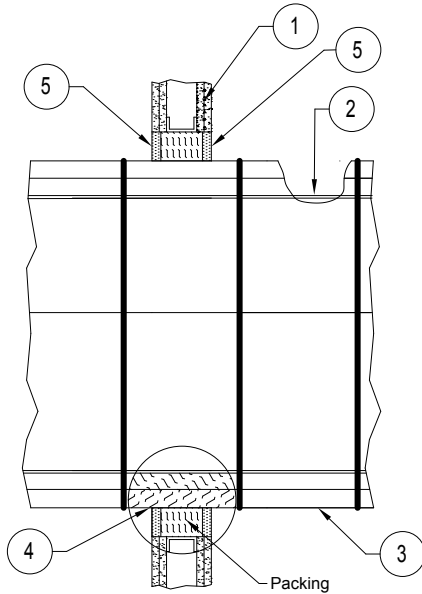

XL Insulation continuous through rated wall assembly

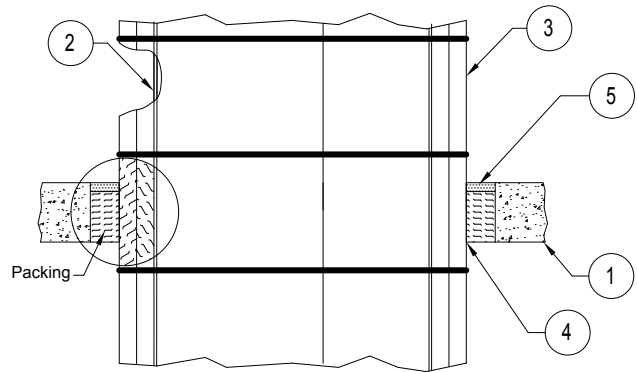

XL Insulation continuous through rated floor/ceiling assembly

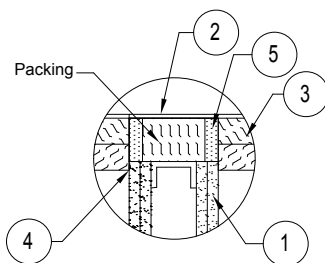

XL insulation terminated on both sides of the rated wall assembly

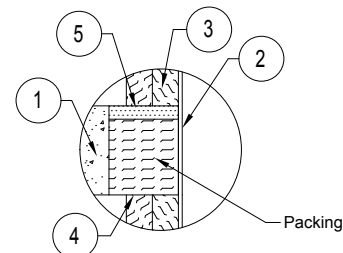

XL insulation terminated at the top and bottom surface of the floor/ceiling assembly

Firestop Designs per ASTM E814 / UL 1479 - Consult UL / ULC Directories for System Details						
UL Listing	F- & T-Rating	(1) Floor/Wall	(2) Penetrant	(3) Enclosure Per	(4) Termination	(5) Firestop Sealant Details
C-AJ-7012	2-hour	Concrete/CMU	84x24; 26 Ga Duct	V19; FRD3; 5; 18	wrap through	1/2 in; STI; Tremco
C-AJ-7014	3-hour	Concrete/CMU	84x24; 26 Ga Duct	V2;	wrap through	1/2 in; STI; Tremco
C-AJ-7019	1 or 2-hour	Concrete/CMU	84x24; 26 Ga Duct	V19; FRD3; 5; 18	terminate at	1/4 in; STI; Tremco
C-AJ-7021	2-hour	Concrete/CMU	49x24; 16 Ga Duct	G18; FRD4; 7	terminate at	1/4 in; STI; Tremco
C-AJ-7095	2-hour	Concrete/CMU	39x39; 22 Ga Duct	V19; FRD3; 5; 18	wrap through	1/4 in; STI Hilti; Rectorseal; Tremco
C-AJ-7098	2-hour	Concrete/CMU	49x24; 16 Ga Duct	G18; FRD4; 7	wrap through	1/4 in; STI; Hilti; Rectorseal; Tremco
F-C-7036	1 or 2-hour	Wood/Gyp Floor	24x12; 16 Ga Duct	G18; FRD4; 7	wrap through	1/4 in; STI; Hilti; Rectorseal; Tremco
F-C-7055	1-hour	Wood/Gyp Floor	4 Dia; 30 Ga Duct	V29; FRD28	wrap through	
W-J-7086	2-hour	Concrete/CMU Wall	100x100; 26 Ga Duct	V19; FRD3; 5; 18	terminate at	1/4 in; STI
W-L-7121	1 or 2-hour	Gyp Wall	30x30; 16 Ga Duct	G18; FRD4; 7	wrap through	1/4 in; STI; Hilti; Rectorseal; Tremco
W-L-7145	1 or 2-hour	Gyp Wall	100x100; 26 Ga Duct	V19; FRD3; 5; 18	terminate at	5/8 in; STI

The integrity of Morgan Thermal Ceramics duct systems is limited to the quality of the installation.
XL003-5

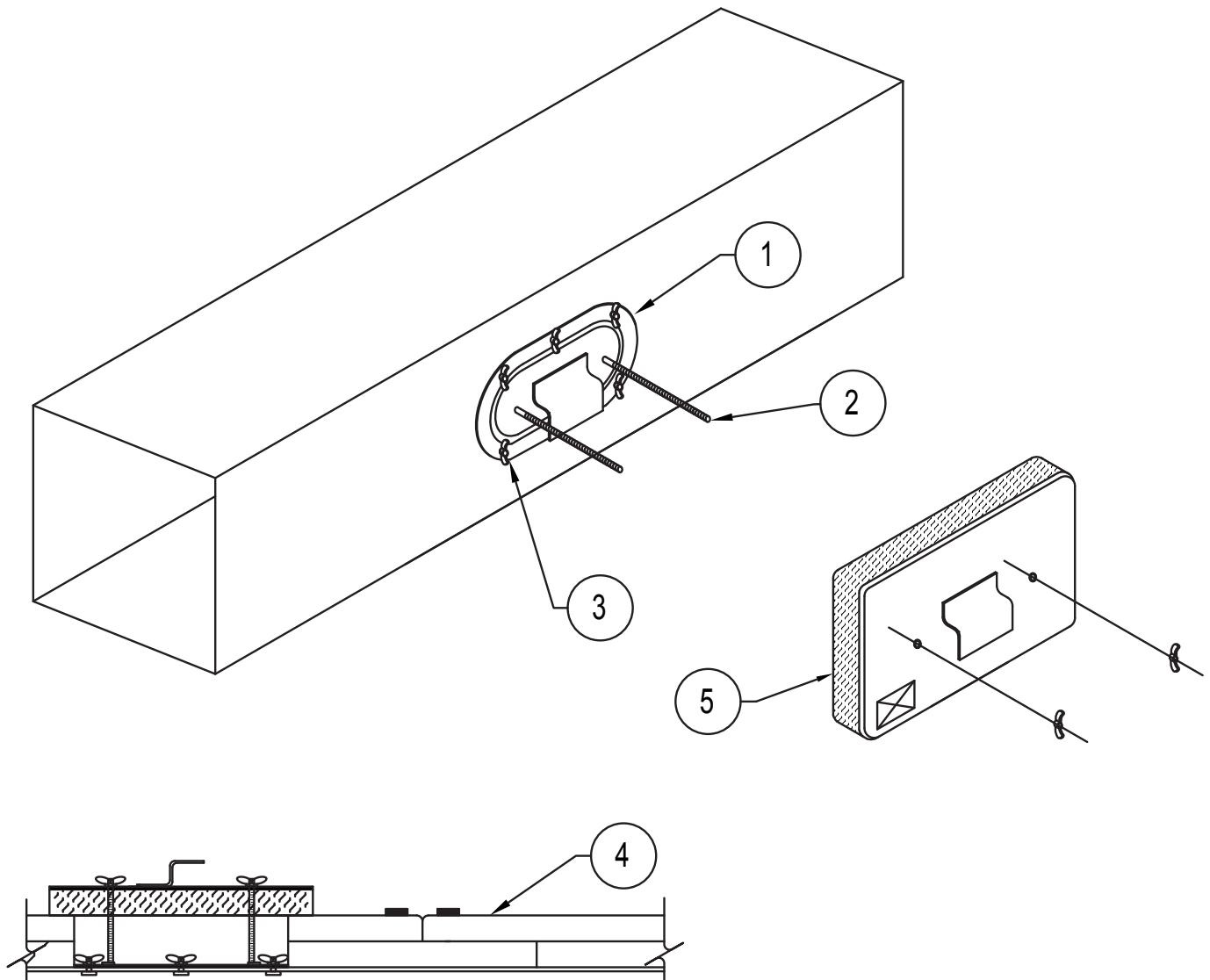

ASTM E 2336 Compliant Enclosure and Door System

FIGURE 3	
1	UL listed FastDoor XL access panel
2	All Thread Rods and wing nuts
3	Retainer Clips with threaded nut and wing bolts
4	Insulation layers as required by UL or ITS Listings
5	FastDoor XL; 1-1/2 inch thick single layer insulation

FastDoor XL1 Access Doors Sizes	
Available Opening Sizes	Ordering Code
10" x 4" Door Opening	*434-6970-033-99X1
10" x 6" Door Opening	434-6970-034-99X1
12" x 8" Door Opening	434-6970-035-99X1
12" x 12" Door Opening	434-6970-036-99X1
16" x 12" Door Opening	434-6970-037-99X1
20" x 20" Door Opening	434-6970-038-99X1
*Special Order; Curved and SS Available	

Access Door Systems Commercial Kitchen Grease Duct Enclosure System

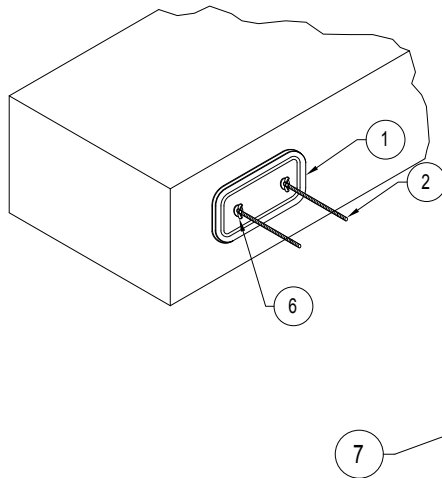

FastDoor XL Insulation Cover

NOTE: Available from Thermal Ceramics
FireMaster Distributors.

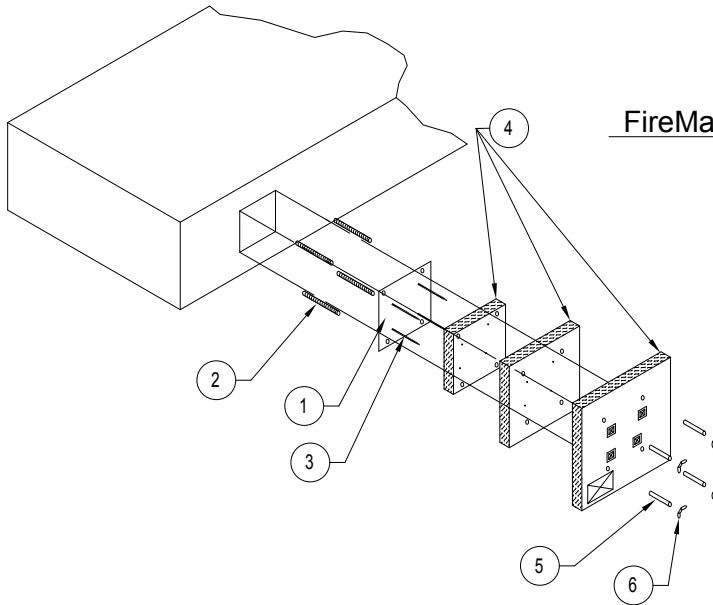

FireMaster Field Fabricated Door System

Note:
Label Required
"Access Door"
Do Not Obstruct

LEGEND	
1	Factory Door by DuctMate (F2); or CHG (Hi-Temp); or code compliant field built door
2	5/16" All Thread Rods.
3	Installation Pins with Speed Clips.
4	Three Layers of FireMaster FastWrap XL Blanket with Minimum 1" (25) Overlaps and All Edges Sealed with Aluminum Tape.
5	Spool Pieces for Threaded Rods
6	Wing Nuts and Washers
7	FastDoor XL; Factory Built Single Layer Insulation Cover (UL Listing G18)

The integrity of the duct wrap insulation product is limited to the quality of the installation

**TYPICAL INSULATION PIN LAYOUT
FOR DUCT SPANS > 24" (610) WIDE
To Prevent Blanket Sag**

SIDE ELEVATION

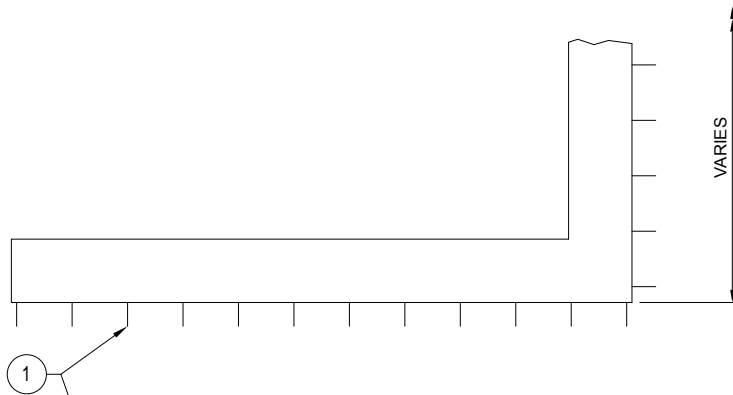

END ELEVATION

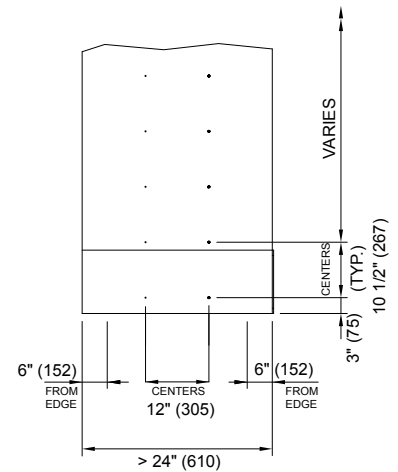

BOTTOM VIEW

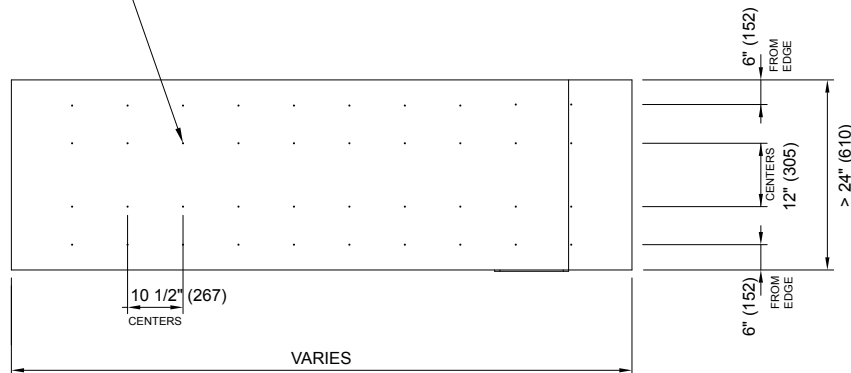

LEGEND

- | | |
|---|---|
| 1 | Minimum 12 gage (3) steel insulation pins |
|---|---|

The integrity of the Morgan Thermal Ceramics duct systems is limited to the quality of the installation.

Commercial Kitchen Grease Duct Enclosure System Air Ventilation Duct Enclosure System

1 Or 2 Or 3 Hour Shaft Alternative / Zero Clearance to Combustibles
2 and 3 Sided Wrap Detail for Attaching to Walls and/or Ceilings

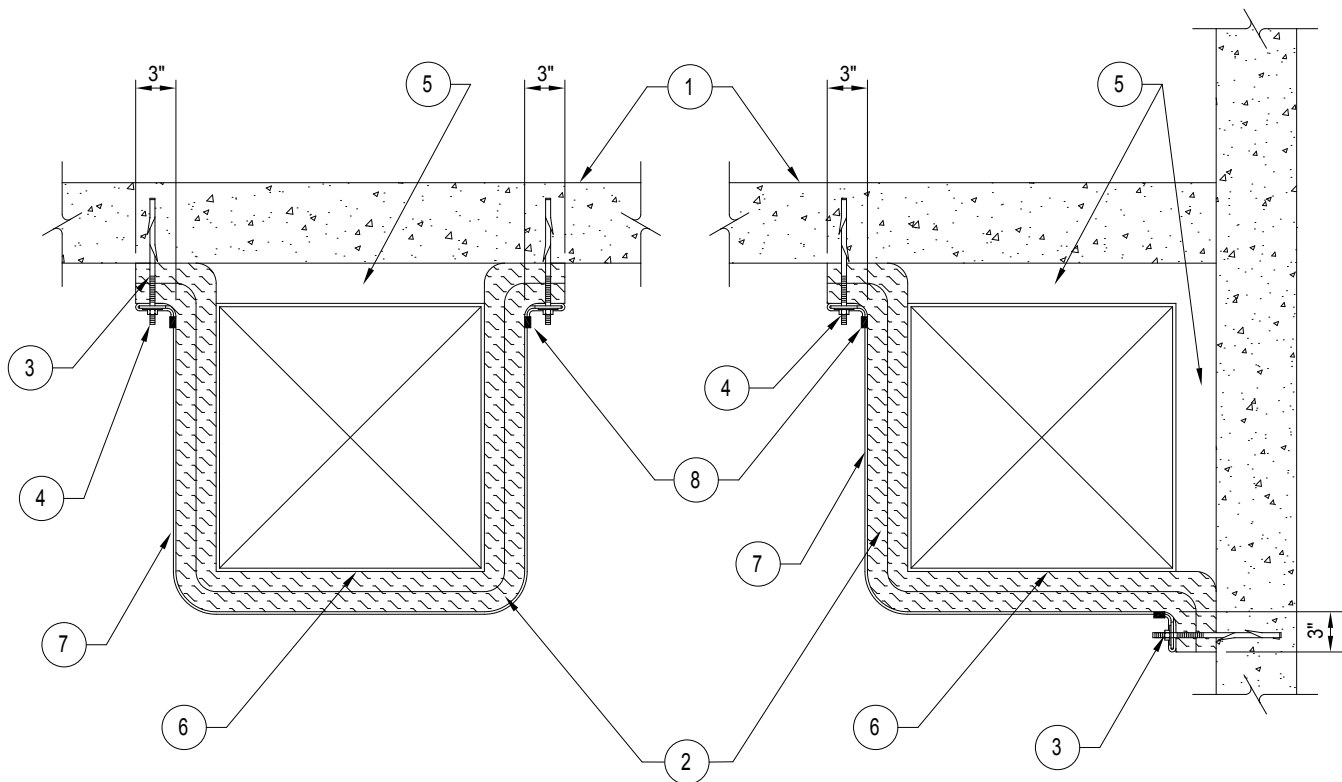

Note: Ducts must be independently supported per code

LEGEND	
1	Rated Concrete floor/ceiling, or wall - with rating equal or greater than enclosure rating
2	Two layers of XL Insulation for Grease Duct Enclosures (install per UL G18)) One layer of XL Insulation for Air Ventilation Duct Enclosures (install per UL V19) Two layers of XL Insulation for 3-hr Air Ventilation Duct Enclosure (install per UL V2)
3	Concrete fastener system
4	3/16" (5) thick x 2" (50) -3" (75) wide bar stock perforated 12" (305) o.c.
5	8" (203) maximum Air Gap
6	Duct
7	Steel banding min. 1/2" (13) wide by 0.015" (0.4) thick.
8	Banding clip

The integrity of Morgan Thermal Ceramics duct systems is limited to the quality of the installation.

**Commercial Kitchen Grease Duct Enclosure System
Air Ventilation Duct Enclosure System
Suggested Wrapping Detail for Vertical Duct with Angle Supports**

Double Layer Installation

Single Layer Installation

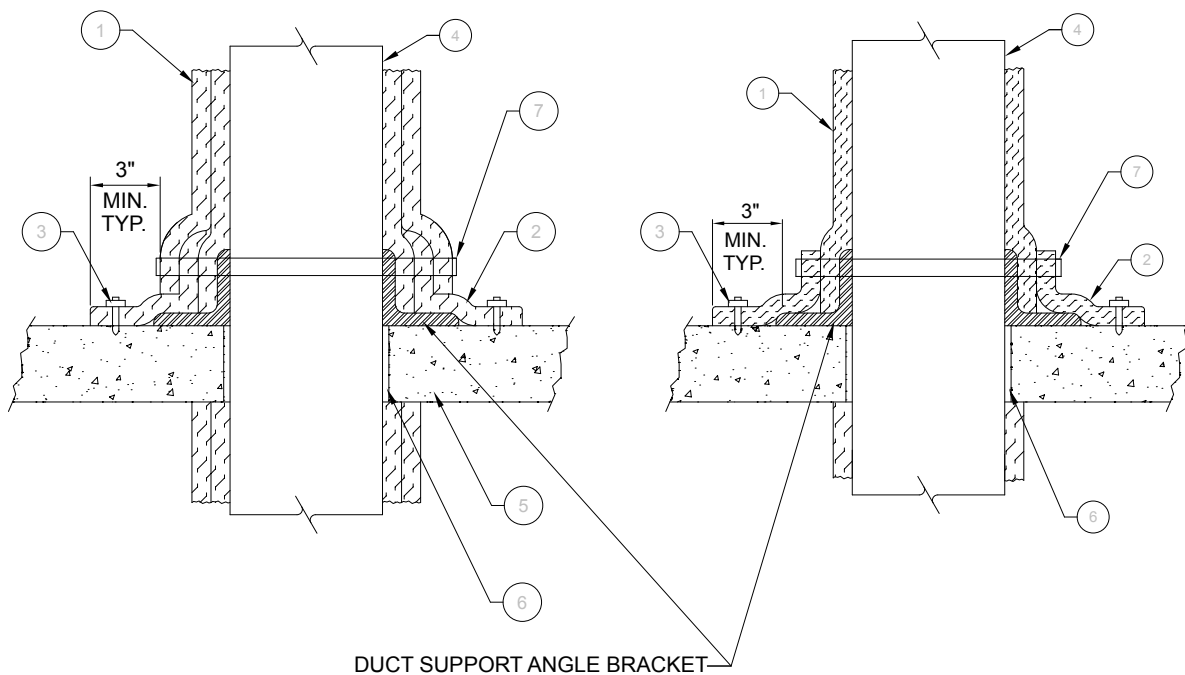

Note:

1. Support Mechanism Should Be In Compliance With The Code.
2. Optional Bracket On Bottom Per Mechanical Designer Requirements.

LEGEND	
1	One layer of XL Insulation for Air Ventilation Duct Enclosures
2	Mechanical fasteners & washers
3	Mechanical fasteners & washers
4	Duct
5	Fire-resistive concrete floor/ceiling assembly
6	Approved through-penetration firestop sealant
7	Steel banding min. 1/2" wide by 0.015" thick

Suggested Installation For Grease Duct Exiting Roof

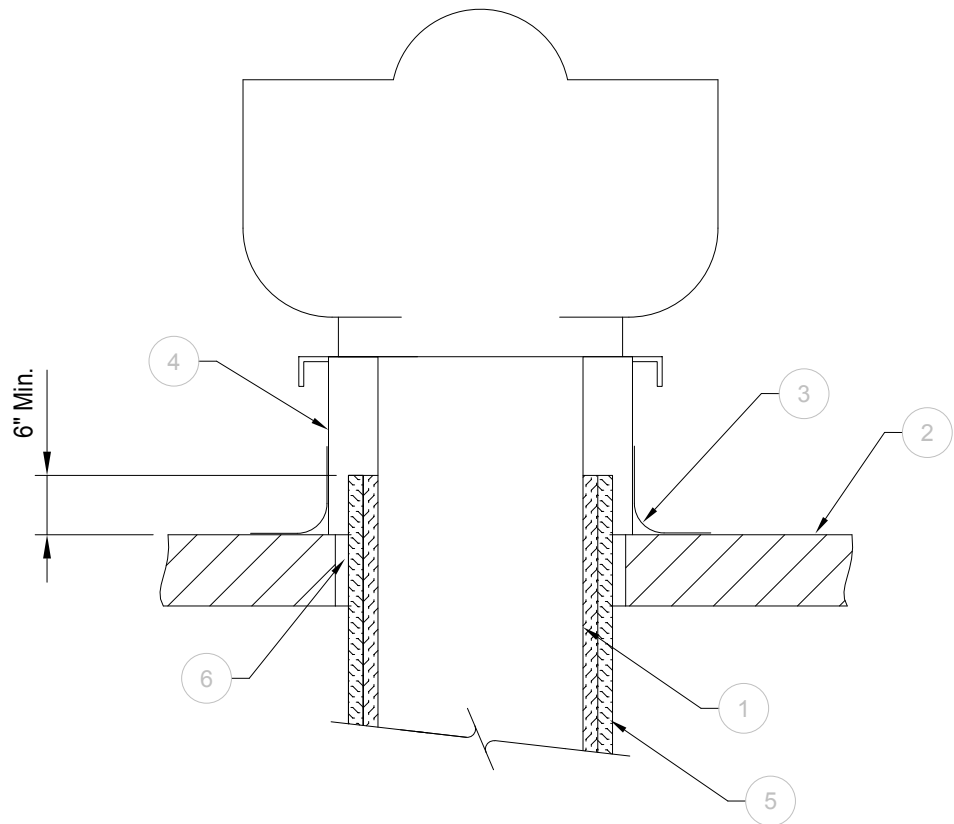

LEGEND	
1	Duct
2	Roof
3	Roof over-flashing
4	Vent flashing
5	Two layers XL Insulation for grease ducts
6	UL Listed Firestop System (only needed for rated roofs)

The integrity of the Morgan Thermal Ceramics duct systems is limited to the quality of the installation.

Detail For Incorporating Sprinkler Lines Into Grease Duct Systems

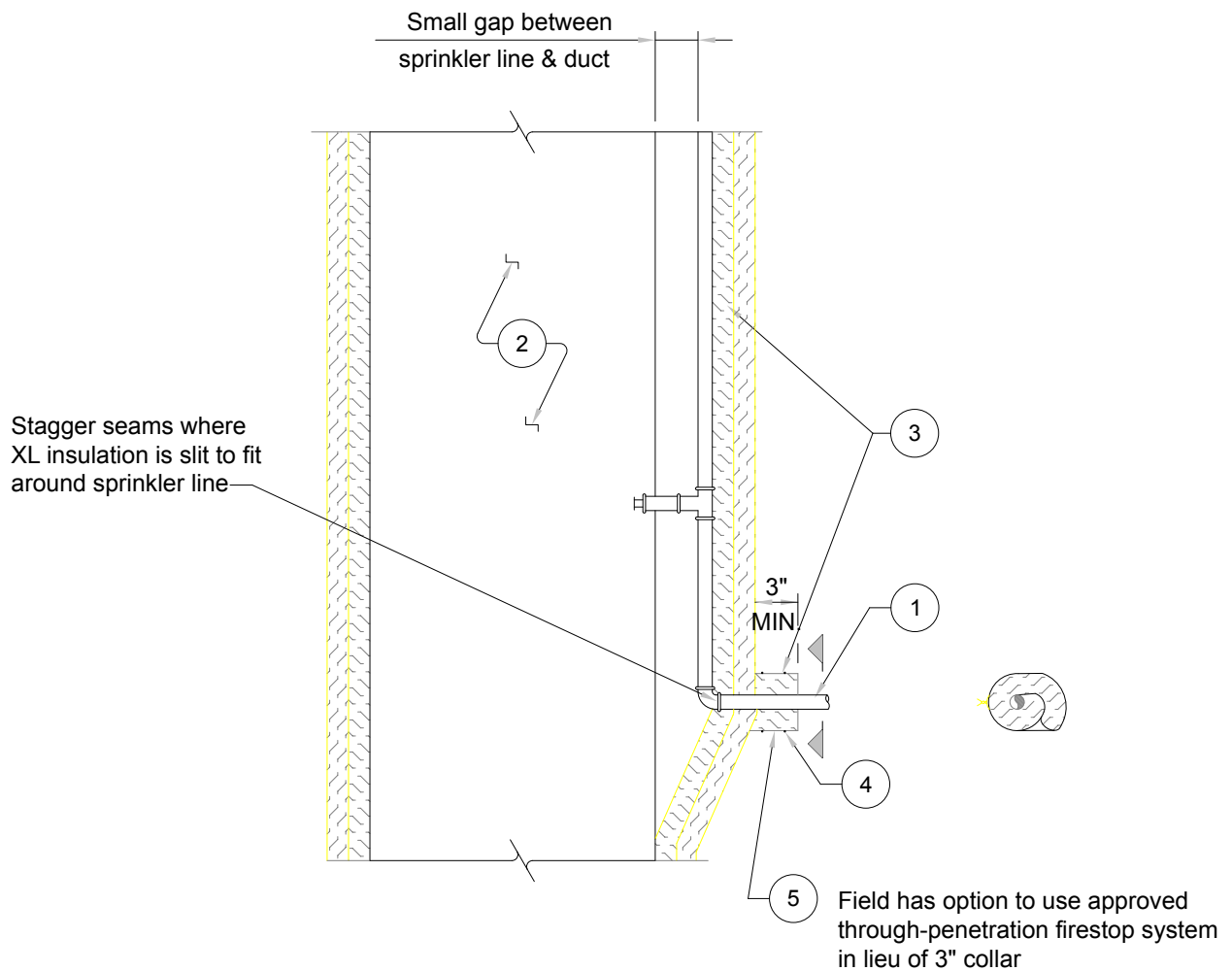

LEGEND	
1	Steel sprinkler line
2	Duct
3	One or Two layers of XL Insulation
4	SS wire ties min. 16 ga.
5	One layer XL Insulation - 3" minimum collar

The integrity of Thermal Ceramics duct systems is limited to the quality of the installation.

**Commercial Kitchen Grease Duct Enclosure System
Air Ventilation Duct Enclosure System
Suggested Installation For Pipe, Conduit, Or Support Hanger
Penetration Of Wrap**

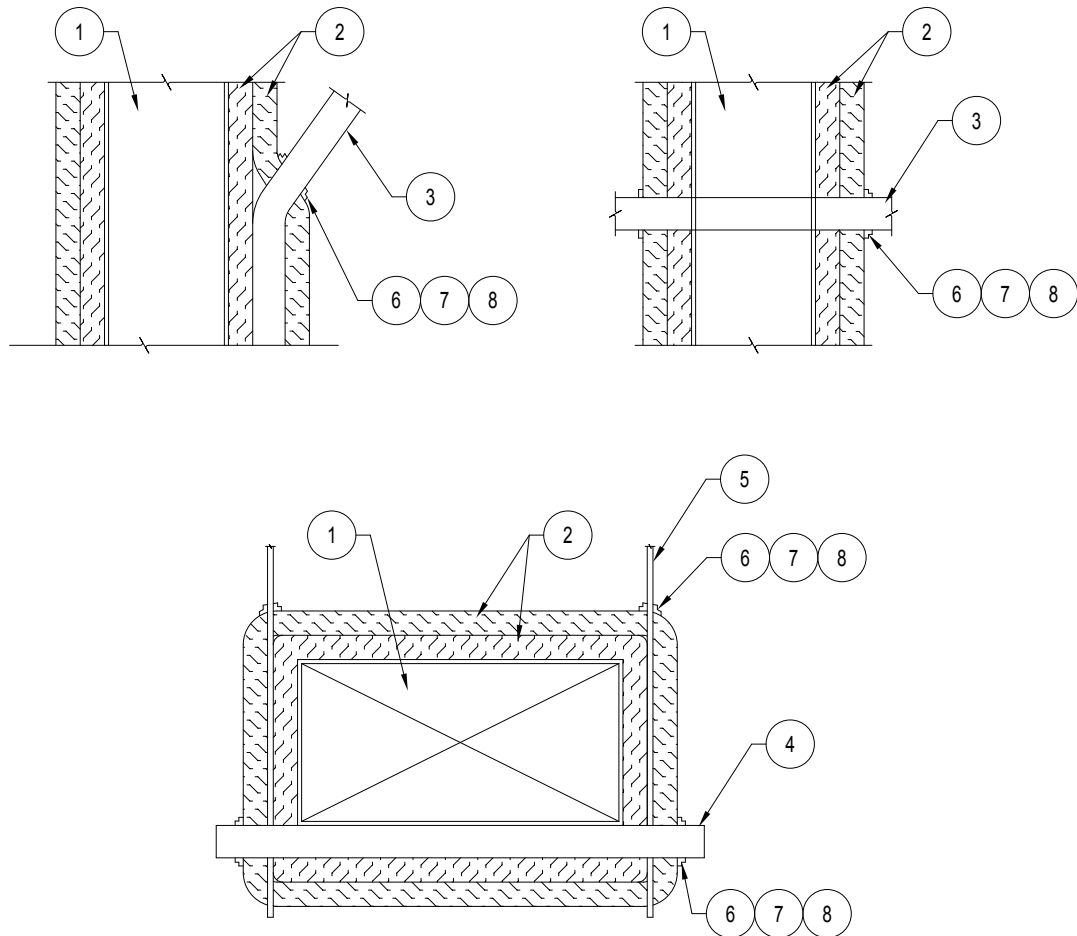

LEGEND	
1	Duct
2	Two layers of XL Insulation for Grease Duct Enclosures One layer of XL Insulation for Air Ventilation Duct Enclosures
3	Non-Combustible Conduit or Pipe
4	Support hanger brackets
5	Support hanger rods (min. 3/8")
6	Filament tape
7	Approved through-penetration firestop system
8	Aluminum tape

The integrity of the Thermal Ceramics duct systems is limited to the quality of the installation.

**Commercial Kitchen Grease Duct Enclosure System
Air Ventilation Duct Enclosure System
Suggested Installation Detail For Rated Shaft Transition**

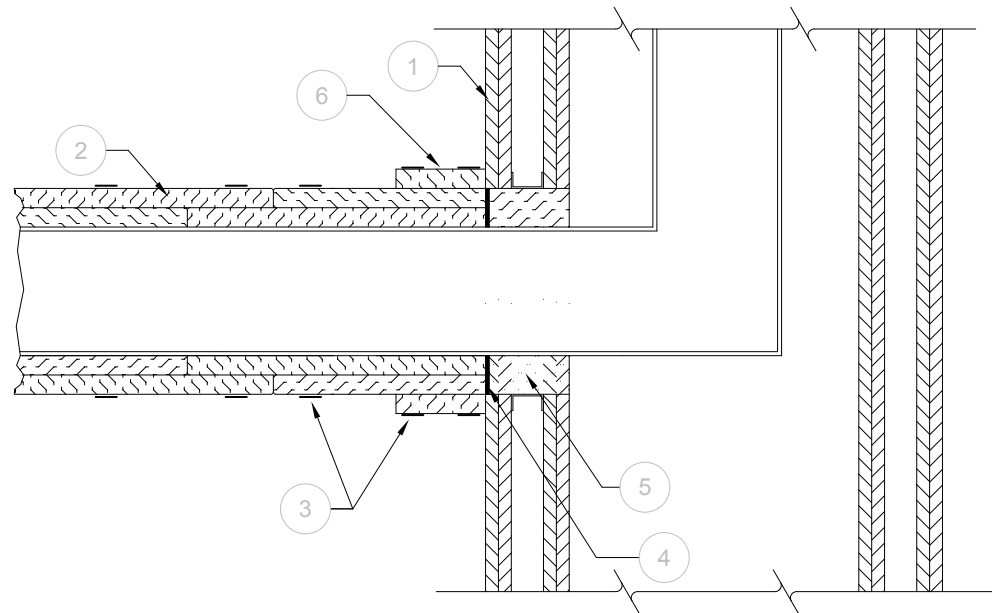

Based on UL System Nos. W-L-7041, W-L-7099, W-L-7121, W-L-7145

LEGEND	
1	Rated Shaft
2	Two layers of XL Insulation for Grease Duct Enclosures (ASTM E2336) One Layer of XL Insulation for Air Ventilation Duct Enclosures
3	Steel banding 1/2" wide min.
4	1/4" approved through-penetration firestop sealant
5	Scrap pieces Of XL Insulation
6	XL Collar (6" Wide)

The integrity of the Morgan Thermal Ceramics duct systems is limited to the quality of the installation.

Suggested Installation Detail For Transition To Rated Shaft

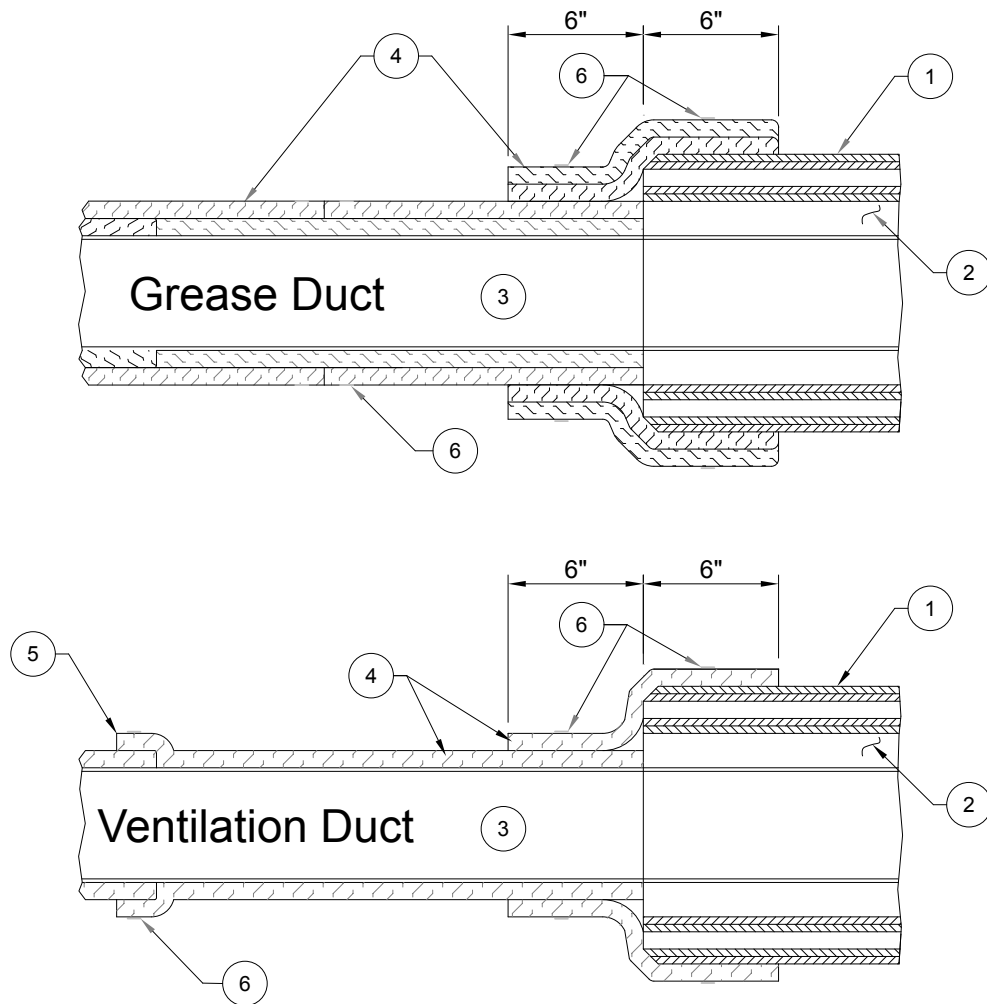

LEGEND	
1	Rated shaft
2	Air gap
3	Duct
4	Two layers of XL Insulation for Grease Duct Enclosures One Layer of XL Insulation for Air Ventilation Duct Enclosures
5	3" minimum overlap
6	Steel banding min. 1/2" wide by 0.015" thick

The integrity of Firemaster duct systems is limited to the quality of the installation.

Suggested Installation Detail For Grease Hoods

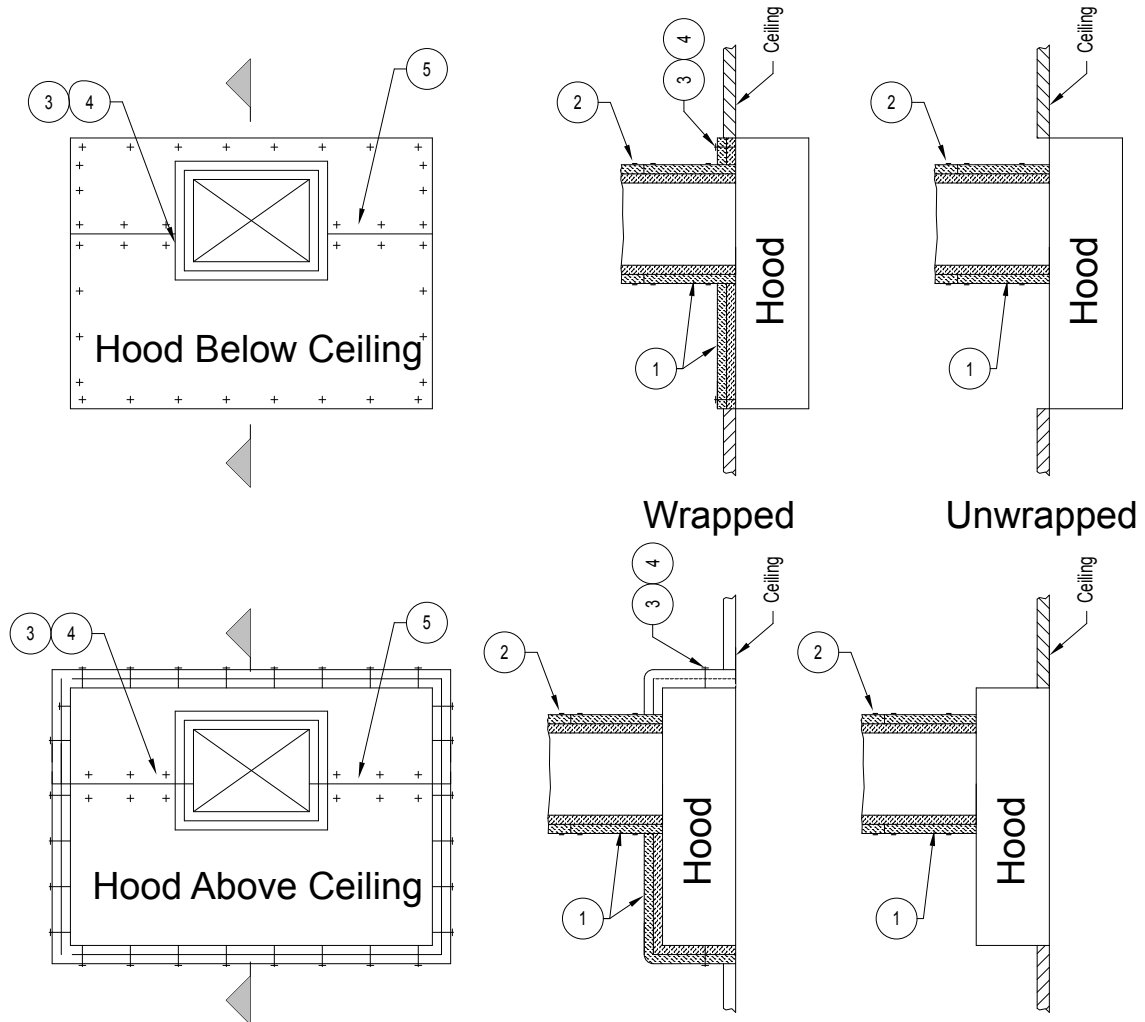

Notes:

All joints should be installed with tight butt joints on both layers, or minimum 3" overlap on outside layer.
 Pins are installed on 10-1/2" o.c., and centered on 3" overlaps or maximum 3" on both sides of outside layer butt joints.
 Hood installation must be approved and in compliance with the code.
 There is no test standard for wrapping grease duct hoods. Approval is subject to the Authority Having Jurisdiction

LEGEND	
1	Two layers XL Insulation installed per UL Listing HNKT-G18
2	Steel banding 1/2" wide min.
3	Minimum 12 gauge steel insulation pins
4	Speed clips
5	Butt Joints (shown) or 3" min perimeter overlap - see note on pin spacing

The integrity of the Thermal Ceramics duct systems is limited to the quality of the installation.

Superior installation methods!

- Less space
- Less labor
- Less material
- Professional appearance

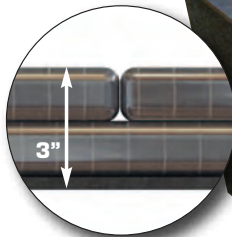

Cross section of applied insulation

Thermal Ceramics installation method



NEW Optimized grease duct enclosure system

- Butt joints, all seams, both layers, no 3" overlaps
- Maximum 3" thickness along all surfaces of the duct
- UL listed for rectangular and round ducts
- UL listed, liquid tight, single layer FastDoor XL for duct access

world leading products - engineered solutions



FastDoor XL for safe and easy duct access

Competitor installation method

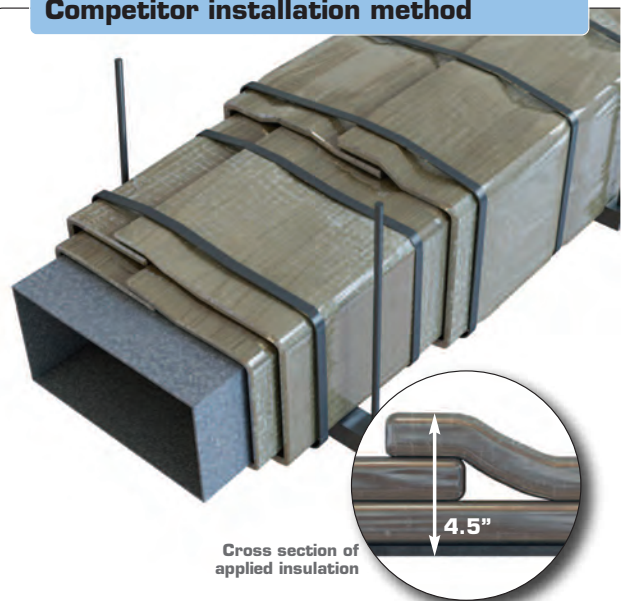

Cross section of applied insulation

Good Installation Example



- Two layers of insulation tight against duct
- 1/2" Stainless steel bands on maximum 12" centers
 - Bands centered on overlaps
 - Duct supports dropped below insulation
- Proper size hanger rod and support, spaced maximum 60" apart
 - Access doors installed at change in direction on duct
 - FastDoor XL system for access doors

Good Installation Examples



- Two layers of insulation tight against duct
- ½" Stainless steel bands on proper spacing
- Hangers dropped outside insulation
- Firestop caulk used to seal penetrations
- FastDoor™ XL system for access doors



- Two layers of insulation tight against duct
- Installed with zero clearance to wood frame
- Insulation properly cut for FastDoor XL installation, tape sealed edges



- Two layers of insulation tight against duct
- ¾" SS Bands on proper spacing
- Insulation properly cut for FastDoor XL installation, tape sealed edges
- Firestop caulk used to seal penetrations



- Single layer for HVAC duct shown
- 6" collars centered over joints, with two bands 1-1/2" from each edge
- Proper hangers, supports, spacing
- Shown using 48" blanket to minimize joints

**Factory Doors and Insulation Covers Recommended (see FastDoor™ XL)
Avoid Common Pitfalls Shown Below**



Insulation cover must be removable
Tape is not sufficient to hold insulation



Tape is not sufficient to hold insulation
Use weld-on pins to attach insulation



Avoid flanges taller than insulation
This typical door is tough to insulate



Duct access must be insulated (not bare)
Shown is a typical factory door



Insulation cover must be easily removable
Banding over doors should be avoided



Code requires door be insulated
This door only has a clearance shield

Assembly No. HNKT.G-18
2-Hour Rating

Classified in accordance with the requirements of **ASTM E 2336-04**, "Standard Test Methods For Fire Resistive Grease Duct Enclosures", with a minimum zero clearance to combustibles rating.

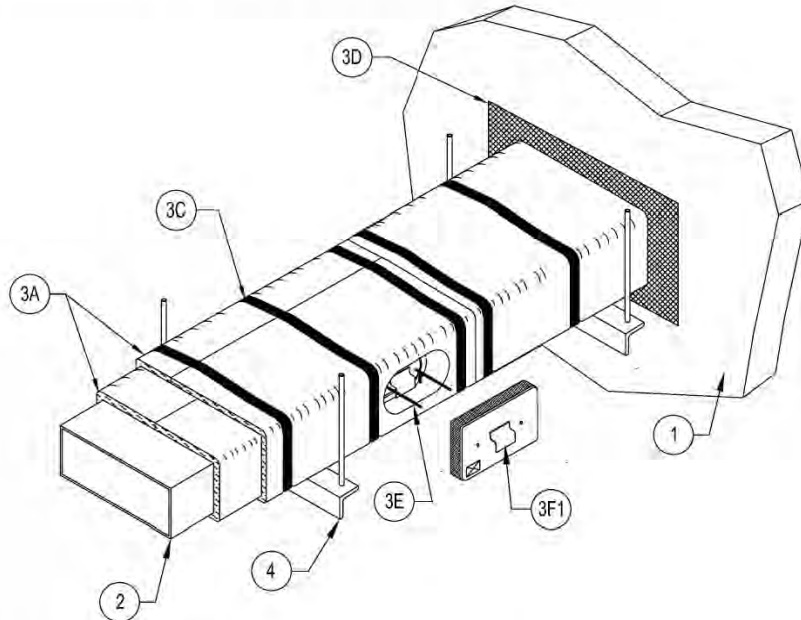

1. **Floor or Wall Assembly** — Min 4-1/2 in. (114 mm) thick reinforced lightweight or normal weight (100-150 pcf, 1600-2400 kg/m³) concrete floor or min 4-3/4 in. (121 mm) thick reinforced lightweight or normal weight concrete wall. Wall may also be constructed of any UL Classified Concrete Blocks. See **Concrete Blocks (CAZT)** category in the Fire Resistance Directory for Mfgs.
2. **Steel Grease Duct** — Min 16 gauge (0.059 in., 1.5 mm thick) rectangular steel duct having dimensions of 24 in. (610 mm) high and 48 in. (1219 mm) wide, or round steel duct having max diameter of 36 in. (914 mm)
3. **Fire Resistive System** — The fire resistive system shall consist of the following:
 - A. **Duct Wrap Materials* — Batts and Blankets*** — Nom 1-1/2 in. (38 mm) thick blanket totally encapsulated within foil-scrim facers. The steel duct shall be wrapped with two layers of duct wrap installed with tightly-butted joints at all transverse and longitudinal joints and with joints offset between the inside and outside layer by a min of 6 in. (152 mm) in accordance with the manufacturer's installation instructions. All cut edges and ends shall be sealed with 3 in. (76 mm) wide pressure sensitive aluminum foil tape.
THERMAL CERAMICS INC — FireMaster FastWrap XL and FastWrap+ or Pyroscat Duct Wrap XL
 - B. **Collars** (Optional, Not Shown)
 - C. **Steel Banding Straps** — Min 1/2 in. (13 mm) wide by 0.015 in. (0.4 mm) thick carbon steel or stainless steel banding straps used in conjunction with min 1 in. (25 mm) long stainless steel crimp clips. Banding straps spaced max 12 in. (305 mm) O.C. and 1-1/2 in. (38 mm) from transverse joints of duct wrap.
 - D. **Firestop System** — When the grease duct passes through a fire rated wall or floor assembly, the through openings shall be firestopped in accordance with System No. C-AJ-7018, C-AJ-7119 or C-AJ-7098.
 - E. **Duct Access Door - Hood and Duct Assemblies#** — (Optional) - Installed per manufacturers' installation instructions.
DUCTMATE INDUSTRIES INC — F2 Access Door, Ultimate Access Door*
COMPONENT HARDWARE GROUP INC — Hi-Temp Access Door

Assembly No. HNKT.G-18
2-Hour Rating

THERMAL CERAMICS INC — FireMaster FastDoor*

- F. **Duct Access Door Insulation** — (Optional, Not Shown) - **Batts and Blankets*** - Nom 1-1/2 (38 mm) thick blanket totally encapsulated within foil-scrim facers, installed in three layers with minimum 1 in. (25 mm) overlaps on each layer and a min 16 gauge (0.059 in., 1.5 mm thick) steel cover plate installed to protect outside layer in accordance with the manufacturer's installation instructions. Assembly is attached to duct with min of two 3/8 in. (10 mm) threaded rods welded to the duct access door (3E).

THERMAL CERAMICS INC — FireMaster Fast Wrap XL and Fast Wrap+ or Pyroscat Duct Wrap XL.

- F1. **Duct Access Door Insulation*** — As an alternate to Item F, assembled insulation cover plate installed in accordance with the manufacturer's installation instructions.

THERMAL CERAMICS INC — FireMaster FastDoor XL or Pyroscat FastDoor XL

4. **Hanger System** — No additional protection is required for hanger systems provided that min 3/8 in. (10 mm) diameter threaded steel hanger rods are used in conjunction with min 2 by 2 by 1/8 in. (51 by 51 by 3 mm) thick steel angle with steel drop in or wedge expansion type masonry anchors.

*Bearing the UL Classification Mark

#Bearing the UL Listing Mark

Assembly No. FRD 7

2-Hour Fire Resistance Rating (Duct A)

(Ratings applicable for Ventilation Ducts installed with or without branches)

Classified in accordance with the requirements of the Standard Method of Fire Resistance Test - Grease Duct Assemblies, CAN/ULC-S144 - 12.

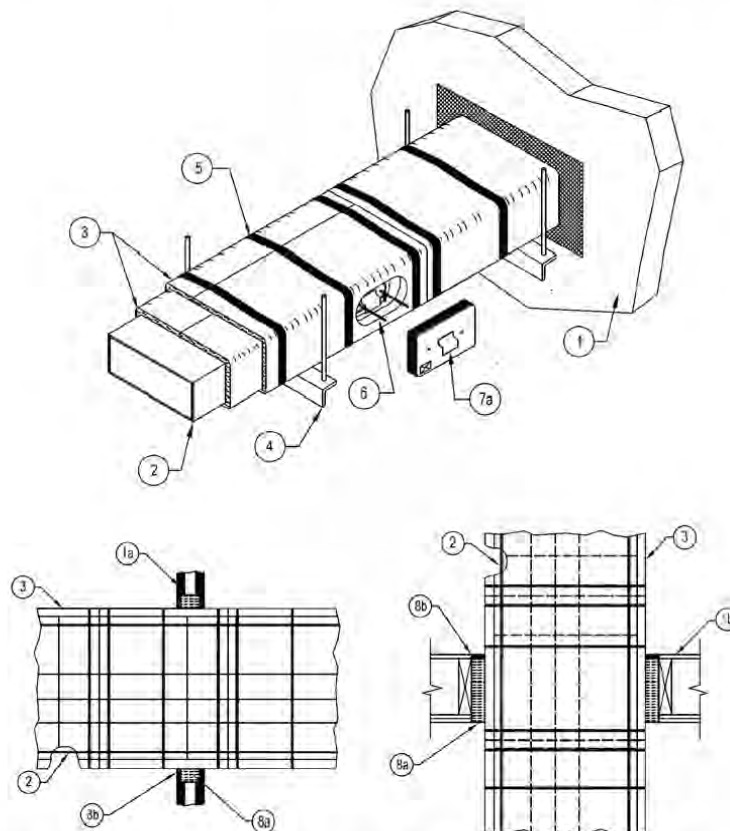

Maximum Size of Duct — 0.75 m² maximum area with no dimension exceeding 1 220 mm.

Support Spacing — 1 500 mm maximum.

Duct Use Limitation — Duct is intended for use in exhaust systems serving commercial and institutional kitchen appliances. When constructed of the materials and in the manner described below, duct system also meets the intent of NFPA 96, Standard for Ventilation Control and Fire Protection of Commercial Cooking Operations, 2011 Edition. Clearance to combustibles is 0 mm.

1. **Floor or Wall Assembly** — Minimum depth or thickness as necessary for the grade of fire separation but not less than 115 mm. Normal-density or low-density concrete. Wall may also be constructed of nominal 200 mm thick concrete block laid up with mortar. **Steel Grease Duct** — Min 16 gauge (0.059 in., 1.5 mm thick) rectangular steel duct having dimensions of 24 in. (610 mm) high and 48 in. (1219 mm) wide, or round steel duct having max diameter of 36 in. (914 mm)

Assembly No. FRD 7

2-Hour Fire Resistance Rating (Duct A)

(Ratings applicable for Ventilation Ducts installed with or without branches)

- a) Or **Wall Assembly** — The fire-rated gypsum wallboard and steel or wood stud assembly shall be constructed of the materials and in the manner described in the individual Wall or Partition design in the ULC Fire Resistance directory.
- b) Or **Floor/Ceiling Assembly** — The fire-rated combustible floor/ceiling assembly shall be constructed of the materials and in the manner described in the individual Floor-Ceiling design in the ULC Fire Resistance directory.
2. **Grease Duct** — Duct to be constructed in accordance with the requirements of the Standard for Ventilation Control and Fire Protection of Commercial Cooking Operations, 1994 Edition. Minimum thickness of steel permitted 1.6 mm thick carbon steel or 1.2 mm thick stainless steel; maximum size of duct 610 mm by 1 220 mm nominal, or 914 mm diameter round.
3. **Duct Insulation** — (HNNZC) — Nominal 38 mm thick Calcia-Magnesia-Silica (CSM) blanket totally encapsulated within foil-scrim facers. The steel duct shall be wrapped with two layers of duct wrap installed with tightly-butted joints at all transverse and longitudinal joints and with joints offset between the inside and outside layer by a min of 152 mm in accordance with the manufacturer's installation instructions. All cut edges and ends shall be sealed with min 76 mm wide pressure sensitive aluminum foil tape.
THERMAL CERAMICS INC — FireMaster FastWrap XL, Pyroscat Duct Wrap XL
4. **Support Rod — Hanger System** — No additional protection is required for hanger systems provided that min 10 mm diameter threaded steel hanger rods are used in conjunction with min 51 by 51 by 3 mm thick steel angle with steel drop in or wedge expansion type masonry anchors.
5. **Steel Banding Straps** — 13 mm wide by 0.4 mm thick carbon steel or stainless steel banding straps used in conjunction with min 25 mm long stainless steel crimp clips. Banding straps spaced max 305 mm O.C. and 38 mm from transverse joints of duct wrap.
6. **Duct Access Door** — Installed per manufacturers' installation instructions.
THERMAL CERAMICS INC — FireMaster DuctDoor*
DUCTMATE INDUSTRIES INC — F2 Access Door, Ultimate Access Door*
COMPONENT HARDWARE GROUP INC — Hi-Temp Access Door
7. a) **Duct Access Door Insulation** — (Optional, Not Shown) - Fabricated from Batts and Blankets* - Nom 38 mm thick blanket totally encapsulated within foil-scrim facers, installed in three layers with minimum 25 mm overlaps on each layer and a 1.5 mm (16 gage) cover plate installed to protect outside layer in accordance with the manufacturer's installation instructions. Assembly is attached to duct on minimum two 10 mm threaded rods welded to the duct access door (3E).
THERMAL CERAMICS INC — FireMaster FastWrap XL, Pyroscat Duct Wrap XL
- b) **Duct Access Door Insulation** — Assembled insulation cover plate installed in accordance with the manufacturer's installation instructions.
THERMAL CERAMICS INC — FireMaster FastDoor XL or Pyroscat FastDoor XL

Assembly No. FRD 7
2-Hour Fire Resistance Rating (Duct A)
(Ratings applicable for Ventilation Ducts installed with or without branches)

Firestop System Installation

The duct shall be installed within the opening such that the annular space between the wrapped duct and the edges of the opening is maximum 76 mm. For installations in gypsum wallboard assemblies, the opening to accommodate the duct shall be framed on all sides using lengths of stud installed between vertical studs and secured to the vertical studs.

For installations in combustible floor/ceiling assemblies, only Option A shall be used. The maximum and minimum annular spaces shall be 82 and 22 mm respectively. The opening to accommodate the duct shall be framed on all sides using lengths of nominal 38 mm by minimum 240 mm wood joists.

Firestop System Installation through Non-Combustible Floor or Combustible or Non-Combustible Wall Opening

8. a). **Firestop Insulation** — (HNNZC) — (Unfaced scrap duct wrap or ULC labelled mineral wool insulation with minimum 64 kg/m³ density compressed 50% minimum and installed into the opening to a minimum depth of 100 mm. Material to be recessed 6.4 mm from top surface of floor or both surfaces of wall to allow for the installation of sealant (Item 8b).

THERMAL CERAMICS INC — FireMaster Fast Wrap XL, Pyroscat Duct Wrap XL

- b). **Firestop Insulation Component** — (Caulk applied over insulation (Item 7a) to a minimum depth of 6.4 mm flush with top surface of floor or symmetrically to both surfaces of wall. Or, Self-leveling silicone sealant, for horizontal penetrations only, applied to a minimum depth of 6.4 mm flush with the top surface of floor slab.

SPECIFIED TECHNOLOGIES INC — SpecSeal 100 or SpecSeal LCI Sealant

A/D FIRE PROTECTION SYSTEMS INC — A/D FIREBARRIER Intumescent Sealant

HILTI CONSTRUCTION CHEMICALS, DIV OF HILTI INC — FS-ONE Sealant

TREMCO INC — Fyre-Sil, Fyre-Sil S/L, TREMstop Acrylic or TREMstop Intumescent Acrylic Sealant

RECTORSEAL — FS 900+ Sealant, FS 1900 Sealant

3M COMPANY — 3M Fire Barrier 2000 or 2000+, 3M Fire Barrier CP25WB+, 3M Fire Barrier 1003

Option A — (Firestop System Installation Through Combustible Floor/Ceiling Opening)

8. a). **Firestop Insulation** — (HNNZC) — (Unfaced scrap duct wrap or ULC labelled mineral wool insulation with minimum 48 kg/m³ density compressed 50% minimum and installed into the opening to a minimum depth of 240 mm. Material to be recessed from surface of floor and of ceiling to accommodate required thickness of sealant (Item 8b).

THERMAL CERAMICS INC — FireMaster Fast Wrap XL, Pyroscat Duct Wrap XL

8. b). **Firestop Insulation Component** — (XHJZC) — (Caulk, sealant applied over insulation (Item 8a) to a minimum depth of 32 mm flush with top surface of floor and to a minimum depth of 16 mm, flush with surface of ceiling.

SPECIFIED TECHNOLOGIES INC — SpecSeal 100 or SpecSeal LCI Sealant

A/D FIRE PROTECTION SYSTEMS INC — A/D FIREBARRIER Intumescent Sealant

HILTI CONSTRUCTION CHEMICALS, DIV OF HILTI INC — FS-ONE Sealant

TREMCO INC — Fyre-Sil, Fyre-Sil S/L, TREMstop Acrylic or TREMstop Intumescent Acrylic Sealant

RECTORSEAL — FS 900+ Sealant, FS 1900 Sealant

3M COMPANY — 3M FireBarrier CP-25WB+ Caulk

*Bearing the ULC Listing Mark

Copyright © 2012 Underwriters Laboratories of Canada Inc



2102 Old Savannah Rd, Augusta, GA
www.morganthermalceramics.com

Technical Support:
(706) 796-4306
firemaster@thermalceramics.com

Reprinted from the ULC Online Directories with
permission from Underwriters Laboratories of Canada Inc.
Created or Modified January 17, 2013



FRD 7
Page 3 of 3

System No. C-AJ-7021

ANSI/UL1479 (ASTM E814)		CAN/ULC S115
F Rating - 2 Hr	T Rating - 2 Hr	FTH Rating - 2 Hr

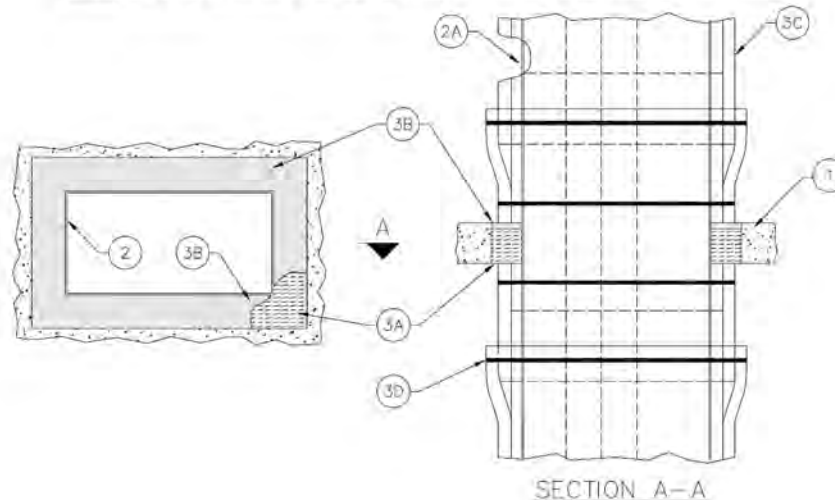

1. **Floor or Wall Assembly** — Min 4-1/2 in. (114 mm) thick reinforced normal weight (140-150 pcf or 2243-2400 kg/m³) concrete floor or min 4-3/4 in. (121 mm) thick reinforced normal weight concrete wall. Wall may also be constructed of any UL Classified **Concrete Blocks***. Max area of opening is 18.75 ft² (1.74 m²) with a max dimension of 90 in. (2.3 m). See **Concrete Blocks (CAZT)** category in the Fire Resistance Directory for Mfgs.
2. **Through-Penetrant** — One steel duct to be installed within the firestop system with an annular space of 3 in. (76 mm). Duct to be rigidly supported on both sides of floor or wall assembly. The following types of through-penetrants may be used:
 - A. **Steel Air Duct** — Min 26 gauge (0.021 in. or 0.53 mm) thick carbon steel duct having a max perimeter dimension of 216 in. (5.5 m) and a max individual dimension of 84 in. (2.13 m). Ducts with any dimension greater than 39 in. (0.99 m), shall be provided with intermediate reinforcement in accordance with SMACNA HVAC Duct Construction Standards. Reinforcement to consist of min 1-1/2 in. (38 mm) by 1-1/2 in. (38 mm) by 1/8 in. (3 mm) thick transverse stiffening angles, approximately 2 in. (51 mm) less in length than the max dimension, screw attached 8 in. (203 mm) OC to the duct 3 in. (76 mm) beyond the top surface of the floor and both surfaces of the wall.
3. **Firestop System** — The firestop system shall consist of the following:
 - A. **Packing Material** — Min 4 in. (102 mm) thickness of unfaced scrap duct wrap material or min 3 pcf (48 kg/m³) mineral wool batt insulation firmly packed into opening as a permanent form between the bare steel duct and the periphery of the opening. Packing material to be recessed from the top surface of the floor or both surfaces of wall as required to accommodate the required thickness of fill material.
 - B. **Fill, Void or Cavity Material* — Sealant** — Min 1/4 in. (6 mm) thickness of fill material applied within the annulus, flush with top surface of floor or both surfaces of wall.
TREMCO INC — Fyre-Sil Sealant or Fyre-Sil S/L Sealant (for floor assemblies only)
 - C. **Duct Wrap Materials*** — Nom 1-1/2 in. (38 mm) thick, 6 pcf (96 kg/m³) ceramic blanket totally encapsulated within foil-scrim facers. The steel duct shall be wrapped with two layers of duct wrap installed in accordance with the manufacturer's installation instructions, maintaining min 3 in. (76 mm) transverse and longitudinal overlaps. The duct wrap shall be tightly butted to the floor or wall on both sides of the assembly. All cut edges and ends shall be sealed with 3 in. (76 mm) wide pressure sensitive aluminum foil tape.
THERMAL CERAMICS INC — FireMaster FastWrap XL and FastWrap+ or Pyroscat Duct Wrap XL
 - D. **Steel Banding Straps** — Min 1/2 in. (13 mm) wide by 0.015 in. (0.38 mm) thick carbon steel banding straps used in conjunction with min 1 in. (25 mm) long stainless steel crimp clips. Banding straps spaced a max 12 in. (305 mm) OC and 1-1/2 in. (38 mm) from transverse joints of duct wrap.

*Bearing the UL Classification Mark

System No. C-AJ-7098

ANSI/UL1479 (ASTM E814)		CAN/ULC S115
F Rating - 2 Hr	T Rating - 2 Hr	FTH Rating - 2 Hr

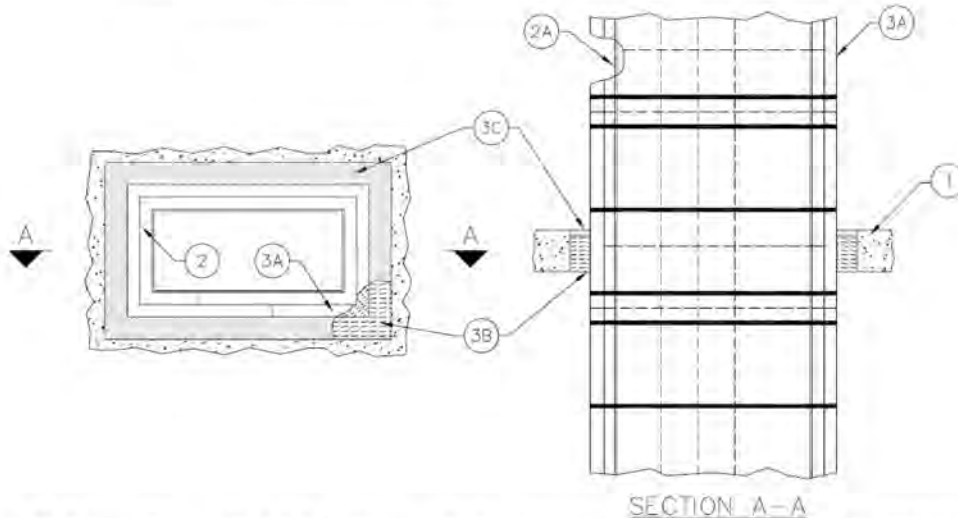

1. **Floor or Wall Assembly** — Min 4-1/2 in. (114 mm) thick reinforced normal weight (140-150 pcf or 2240-2400 kg/m³) concrete floor or min 4-3/4 in. (121 mm) thick reinforced normal weight concrete wall. Wall may also be constructed of any UL Classified **Concrete Blocks***. Max area of opening is 22.6 ft² (2.1 m²) with max dimension of 57 in. (1.45 m). See **Concrete Blocks (CAZT)** category in the Fire Resistance Directory for Mfgs.
2. **Through-Penetrant** — Max 24 by 49 in. (0.61 by 1.24 m) by min 060 in. (1.5 mm) thick steel grease duct. One steel grease duct to be installed either concentrically or eccentrically within the firestop system. Duct to rigidly supported on both sides of floor or wall assembly.
3. **Firestop System** — The firestop system shall consist of the following:
 - A. **Duct Wrap Materials*** — Nom 1-1/2 in. (38 mm) thick ceramic blanket totally encapsulated within foil-scrim facers. The steel duct shall be wrapped with two layers of duct wrap installed in accordance with Grease Duct Assembly No. G-18. See Grease Duct Assemblies in Volume 2 of the Fire Resistance Directory. The annular space between the insulated duct and the periphery of the opening shall be a min of 1/2 in. (13 mm) to a max of 4-3/4 in. (121 mm).
THERMAL CERAMICS INC — FireMaster FastWrap XL and FastWrap+ or Pyroscat Duct Wrap XL
 - B. **Packing Material** — Min 4-1/4 in. (108 mm) thickness of unfaced scrap duct wrap material firmly packed into opening as a permanent form. Packing material to be recessed from the top surface of the floor or from both surfaces of wall as required to accommodate the required thickness of fill material.
 - C. **Fill, Void or Cavity Material*** — **Sealant** — Min 1/4 in. (6 mm) thickness of fill material applied within the annulus, flush with top surface of floor or with both surfaces of wall.
SPECIFIED TECHNOLOGIES INC — Pensil 300 Sealant or SpecSeal Series SIL300 Sealant
HILTI CONSTRUCTION CHEMICALS, DIV OF HILTI INC — FS ONE Sealant
RECTORSEAL — 835+ Sealant
TREMCO INC — Fyre-Sil Sealant or Fyre-Sil S/L Sealant (for floor assemblies only)

*Bearing the UL Classification Mark

System No. F-C-7036

ANSI/UL1479 (ASTM E814)	CAN/ULC S115
F and T Rating – 1 and 2 Hr (See Item 1)	FTH Rating - 2 Hr

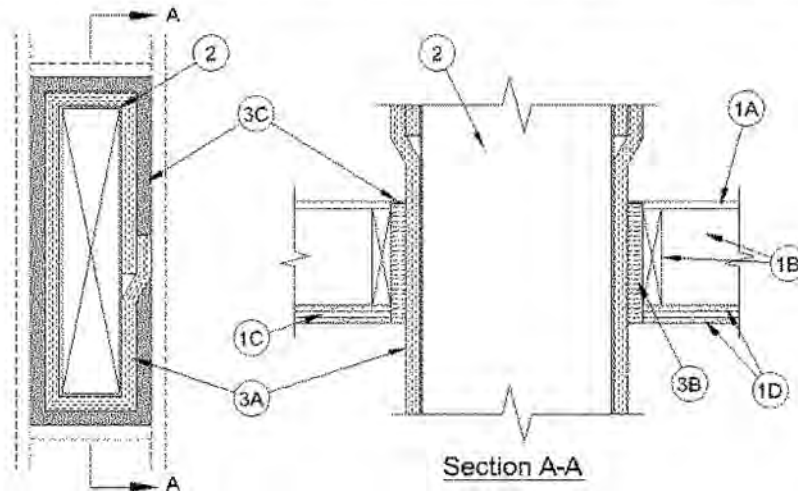

1. **Floor-Ceiling Assembly** — The 1 hr fire-rated solid or trussed lumber joist floor-ceiling assembly shall be constructed of the materials and in the manner specified in the individual L500 Series Floor-Ceiling Designs in the UL Fire Resistance Directory. The 2 hr fire rated wood joist floor-ceiling assembly shall be constructed of the materials and in the manner specified in Design No. L505, L511 or L536 in the UL Fire Resistance Directory. The general construction details of the floor-ceiling assembly are summarized below:
 - A. **Flooring System** — Lumber or plywood subfloor with finish floor of lumber, plywood or **Floor Topping Mixture*** as specified in the individual Floor-Ceiling Design. Max area of floor opening is 435 sq in. (0.28 m²) with a max dimension of 30 in. (762 mm).
 - B. **Wood Joists** — For 1 hr fire rated floor-ceiling assemblies nom 10 in. (254 mm) deep (or deeper) lumber, steel or combination lumber and steel joists, trusses or **Structural Wood Members*** with bridging as required and with ends firestopped. For 2 hr fire rated floor-ceiling assemblies, nom 2 by 10 in. (51 by 254 mm) lumber joists spaced 16 in. (406 mm) OC with nom 1 by 3 in. (25 by 76 mm) lumber bridging and with ends firestopped. Additional framing member to be installed to form a rectangular opening around the through penetrant.
 - C. **Furring Channels** — In 2 hr fire rated assemblies, resilient galv steel furring installed perpendicular to wood joists between first and second layers of gypsum board (Item 1D). Furring channels spaced max 24 in. (610 mm) OC. When required as specified in the individual 1 hr fire rated Floor-Ceiling Design, resilient galv steel furring installed perpendicular to wood joists between gypsum board and wood joists. Furring channels spaced max 24 in. (610 mm) OC. If furring channels are used within the assembly, additional furring channels to be installed around the periphery of the opening.
 - D. **Gypsum Board*** — Nom 4 ft (1.2 m) wide by 5/8 in. (16 mm) thick as specified in the individual Floor-Ceiling Design. First layer of gypsum board secured to wood joists or furring channels as specified in the individual Floor-Ceiling Design. Second layer of gypsum board (2 hr fire rated assembly) screw-attached to furring channels as specified in the individual Floor-Ceiling Design. Max area of ceiling opening is 435 sq in. (0.28 m²) with a max dimension of 30 in. (762 mm).

The hourly F and T Ratings of the firestop system are equal to the hourly fire rating of the floor-ceiling in which it is installed.
2. **Steel Duct** — One steel duct to be centered within the firestop system. Steel duct to be rigidly supported on both sides of floor-ceiling assembly. The following types of steel ducts may be used:
 - A. **Steel Air Duct** — Min 26 gauge (0.5 mm) galv steel duct having a max perimeter dimension of 63 in. (1.6 m) and a max individual dimension of 24 in. (610 mm).

System No. F-C-7036

- B. **Steel Grease Duct** — Min 16 gauge (1.5 mm) thick carbon steel duct having a max perimeter dimension of 63 in. (1.6 m) and a max individual dimension of 24 in. (610 mm).
3. **Firestop System** — The firestop system shall consist of the following:
- A. **Duct Wrap Materials*** — Nom 1-1/2 in. (38 mm) thick blanket totally encapsulated within foil-scrim facers. The steel grease duct shall be wrapped with one layer of duct wrap installed in accordance with Grease Duct Assembly No. G-18. See Grease Duct Assemblies in Vol. 2 of the Fire Resistance Directory. The steel air duct shall be wrapped with one layer of duct wrap installed in accordance with Ventilation Assembly No. V-19. See Ventilation Duct Assemblies in Vol. 2 of the Fire Resistance Directory. The annular space between the insulated steel duct and the periphery of the opening shall be nom 1-1/2 in. (38 mm).
THERMAL CERAMICS INC — FireMaster FastWrap XL and FastWrap+ or Pyroscat Duct Wrap XL
- B. **Packing Material** — Min 10-3/8 in. (264 mm) and 11-5/8 in. (295 mm) thickness of unfaced scrap duct wrap material compressed 50 percent into opening as a permanent form between the insulated steel duct and the periphery of the opening for 1 and 2 hr fire rated floor-ceiling assemblies, respectively. At point contact location between overlap of duct wrap material and floor-ceiling assembly, packing material shall be firmly packed to max extent possible on both sides of the floor-ceiling assembly. Packing material to be installed flush with bottom surface of ceiling and recessed from top surface of floor to accommodate the required thickness of fill material.
- C. **Fill, Void or Cavity Material* — Sealant** — Min 1/4 in. (6 mm) thickness of fill material applied within annulus on top surface of floor. A min 1/4 in. (6 mm) diam bead of sealant shall be applied at the plywood floor/insulated steel duct interface on both surfaces of floor-ceiling assembly.
THERMAL CERAMICS INC — FireMaster Putty
SPECIFIED TECHNOLOGIES INC — Pensil 300 Sealant or SpecSeal Series SIL300 Sealant
HILTI CONSTRUCTION CHEMICALS, DIV OF HILTI INC — FS ONE Sealant
RECTORSEAL — 835+ Sealant
TREMCO INC — Fyre-Sil, TREMstop Acrylic or Intumescent Acrylic Sealant, FyreCaulk or TREMstop IA+

*Bearing the UL Classification Mark

System No. W-L-7121

ANSI/UL1479 (ASTM E814)	CAN/ULC S115
F- and T- Rating – 1 and 2 Hr (See Item 1)	FTH Rating - 2 Hr

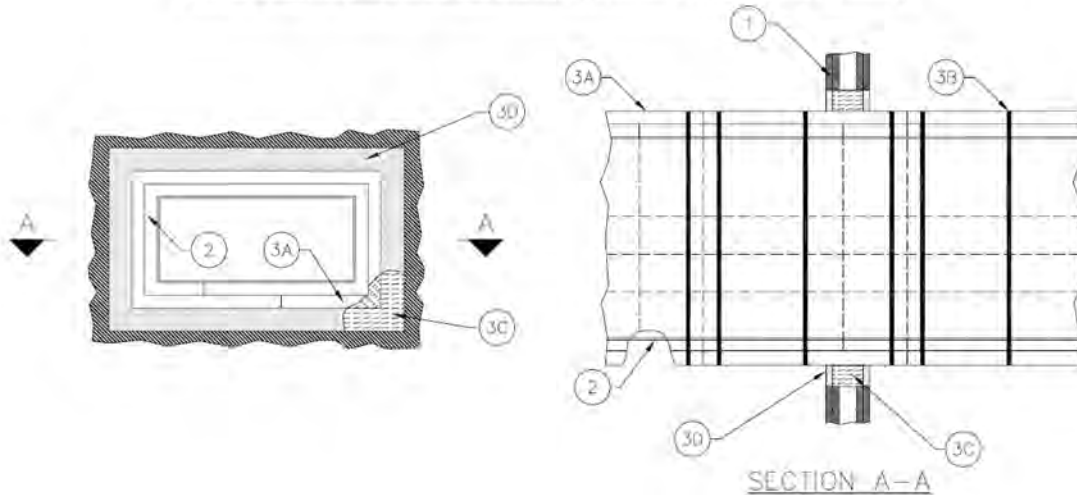

1. **Wall Assembly** — The 1 or 2 hr fire rated gypsum board/stud wall assembly shall be constructed of the materials and in the manner specified in the individual U400, V400 or W400 Series Wall and Partition Designs in the UL Fire Resistance Directory and shall include the following construction features.
 - A. **Studs** — Wall framing shall consist of min 3-1/2 in. (89 mm) wide steel studs. Steel studs to be spaced max 24 in. (610 mm) OC. Additional framing members shall be used to completely frame around opening.
 - B. **Gypsum Board*** — For 1 hr assembly, one layer of min 5/8 in. (16 mm) thick gypsum board as required in the individual Wall and Partition Design. For 2 hr assembly, two layers of min 5/8 in. (16 mm) thick gypsum board as required in the individual Wall and Partition Design. Max area of opening is 8.44 ft² (7.8 m) with max dimension of 38 in. (0.96 m).

The hourly F and T Rating of the firestop system is equal to the hourly fire rating of the wall assembly in which it is installed.
2. **Through Penetrant** — One steel duct to be installed within the firestop system. Duct to be rigidly supported on both sides of wall assembly. The following types of steel ducts may be used:
 - A. **Steel Air Duct** — Min 26 gauge (0.5 mm) galv steel duct having a max perimeter dimension of 108 in. (2.74 m) and a max individual dimension of 30 in. (762 mm).
 - B. **Steel Grease Duct** — Min 16 gauge (0.059 in. or 1.5 mm) thick carbon steel duct having max perimeter dimension of 108 in. (2.74 m) and a max individual dimension of 30 in. (0.76 m). **Grease duct assemblies for use only in 2 hr rated walls.**
3. **Firestop System** — The firestop system shall consist of the following:
 - A. **Duct Wrap Materials*** — Nom 1-1/2 in. (38 mm) thick, 6 pcf, (96 kg/m³) ceramic blanket totally encapsulated within foil-scrim facers. The steel grease duct shall be wrapped with two layers of duct wrap per Grease Duct Assembly G18. The steel air duct shall be wrapped with one layer of duct wrap installed in accordance with Ventilation Assembly No. V-19. The annular space between the insulated duct and the periphery of the opening shall be min 0 in. (point contact) to max 2 in. (51 mm).
THERMAL CERAMICS INC — FireMaster FastWrap XL and FastWrap+ or Pyroscat Duct Wrap XL
 - B. **Steel Banding Straps** — Min 1/2 in. (13 mm) wide by 0.015 in. (0.38 mm) thick carbon steel banding straps used in conjunction with min 1 in. long stainless steel crimp clips. Banding straps spaced max 12 in. (305 mm) OC and 1-1/2 in. (38 mm) from transverse joints of duct wrap.
 - C. **Packing Material** — Min 3-1/2 in. (89 mm) thickness of unfaced scrap duct wrap material compressed 50 percent into opening as a permanent form between the insulated steel duct and the periphery of the opening. Packing material

System No. W-L-7121

shall be firmly packed to max extent possible at gypsum board/insulated steel duct interface on both sides of the wall. Packing material to be recessed from both surfaces of wall to accommodate the required thickness of fill material.

- D. **Fill, Void or Cavity Material*— Sealant** — Min 1/4 in. (6 mm) thickness of fill material applied within annulus, flush with both surfaces of wall assembly. A min 1/4 in. (6 mm) diam bead of sealant shall be applied at the gypsum board/insulated duct interface on both surfaces of wall assembly.

SPECIFIED TECHNOLOGIES INC — Pensil 300 Sealant or SpecSeal Series SIL300 Sealant

HILTI CONSTRUCTION CHEMICALS, DIV OF HILTI INC — FS ONE Sealant

RECTORSEAL — 835+ Sealant

TREMCO INC — Fyre-Sil Sealant or Fyre-Sil S/L Sealant (for floor assemblies only)

*Bearing the UL Classification Mark

Assembly No. HNLJ.V-19
2-Hour Rating; Duct A; Ventilation Duct With or Without Branches

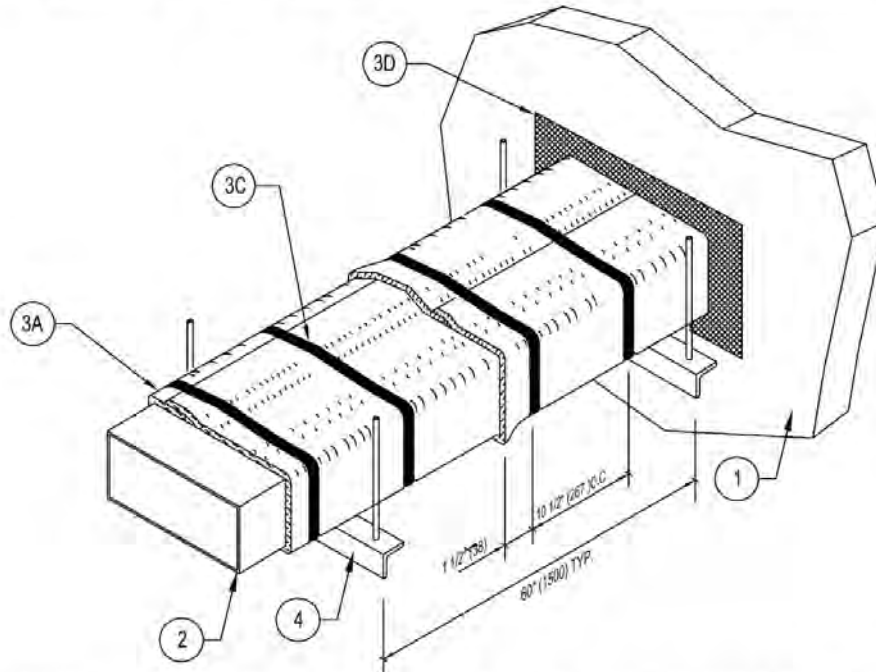

1. **Floor or Wall Assembly** — Floor or Wall Assembly — Min 4-1/2 in. (114 mm) thick reinforced lightweight or normal weight (100-150 pcf or 1600-2400 kg/m³) concrete floor or min 4-3/4 in. (121 mm) thick reinforced lightweight or normal weight concrete wall. Wall may also be constructed of any UL Classified Concrete Blocks. See Concrete Blocks (CAZI) category in the Fire Resistance Directory for Mfgs.
2. **Steel Air Duct** — Min 0.030 in. (No. 22 gauge or 0.71 mm) thick (or heavier) rectangular steel duct having a max width to height ratio of 4 to 1 with max individual dimension of 85 in (2160 mm) and max cross-section area of 14.2 sq ft (1.32 m²), or round steel air duct having a max diameter of 50 in. (1270 mm) constructed in accordance with SMACNA HVAC Duct Construction standards. The sections shall be assembled using bolted flanges or SMACNA approved Transverse Joint Reinforcements. Duct to be rigidly supported in accordance with SMACNA requirement and as specified in Item 4.)
3. **Fire Resistive System** — The fire resistive system shall consist of the following:
 - A. **Duct Wrap Materials*** — **Batts and Blankets*** — Nom 1-1/2 in. (38 mm) thick, 6 pcf (96 kg/m³) blanket totally encapsulated within foil-scrim facers. The steel duct shall be wrapped with one layer of duct wrap installed with 3 in. (76 mm) transverse and longitudinal overlaps, or tightly butted transverse joints, in accordance with the manufacturer's installation instructions. All cut edges and ends shall be sealed with 3 in. (76 mm) wide pressure sensitive aluminum foil tape. For ducts with any dimension greater than 39 in.(991 mm), a second layer of duct wrap shall abut the firestop and extend min 12 in. (305 mm) above and below floor slab or both surfaces of wall.
THERMAL CERAMICS INC — FireMaster FastWrap XL and FastWrap+ or Pyroscat Duct Wrap XL
 - B. **Collars** — Fabricated from Batts and Blankets* — Nom 1-1/2 in. (38 mm) thick, 6 pcf (96 kg/m³), 6 in. (152 mm) wide blanket totally encapsulated within foil-scrim facers. The transverse butt joints shall be wrapped using a collar. The butt joint shall be located nom 3 in. (76 mm) from the edge of the collar. The collar shall be installed with 3 in. (76 mm) longitudinal overlaps. All cut edges and ends shall be sealed with 3 in. (76 mm) wide pressure sensitive aluminum foil tape.
THERMAL CERAMICS INC — FireMaster FastWrap XL and FastWrap+ or Pyroscat Duct Wrap XL

Assembly No. HNLJ.V-19

2-Hour Rating; Duct A; Ventilation Duct With or Without Branches

- C. **Steel Banding Straps** — Min 1/2 in. (13 mm) wide by 0.015 in. (0.38 mm) thick stainless or carbon steel banding straps used in conjunction with min 1 in. (25 mm) long stainless steel crimp clips. Banding straps spaced a max 12 in. (305 mm) OC and 1-1/2 in. (38 mm) from edges of collars.
- C1. **Steel Pins** — (Not shown)—As an alternate to steel banding straps, for use with the butt joint collar technique, min 0.135 in. (3.4 mm) thick, 6 in. (152 mm) long steel insulation pins used in conjunction with 1-1/2 by 1-1/2 in. (38 by 38 mm) square or 1-1/2 in. (38 mm) diameter, 0.016 in. (.40 mm) thick, galvanized steel speed clips. Pins spaced 1-1/2 in. (38 mm) either side of the butt joint and 10 in. (254 mm) max, transversely around the duct, to secure the duct wrap and collar. Additional pins spaced 12 in. (305 mm) max between collars, required to support duct wrap on duct underside and to secure longitudinal lap. Pins installed in accordance with the manufacturers installation instructions.
- D. **Firestop System** — When the ventilation duct passes through a fire rated wall or floor assembly, the through openings shall be firestopped in accordance with System No. C-AJ-7012, C-AJ-7095 or W-J-7086. Ducts with a dimension greater than 39 in. (991 mm) shall be firestopped in accordance with System No. C-AJ-7012 or W-J-7086. See Through—Penetration Firestop Systems in Vol. 2 of the Fire Resistance Directory.
- 4. **Hanger System** — Trapeze support hangers shall be used and spaced a maximum of 60 in. (1500 mm) OC. Hanger rods or straps shall be anchored with steel drop in or wedge expansion type masonry anchors embedded to the depth required by the anchor manufacturer. No additional protection is required for hangers and supports meeting the requirements of the table below.

Hanger Cross Section	Maximum Perimeter of Duct, in. (m)	Trapeze Support
1 in. by 16 ga strap	100 (2.54)	
1/4 in. (6 mm) threaded rod	50 (1.27)	1-1/2 by 1-1/2 by 3/16 in. (38 by 38 by 4.8 mm) angle
3/8 in. (10 mm) threaded rod	150 (3.81)	1-1/2 by 1-1/2 by 3/16 in. (38 by 38 by 4.8 mm) angle
1/2 in. (13 mm) threaded rod	218 (5.54)	2 by 2 by 1/4 in. (51 by 51 by 6 mm) angle

*Bearing the UL Classification Mark

Assembly No. FRD 3
2-Hour Fire Resistance Rating (Duct A)
(Ratings applicable for Ventilation Ducts installed with or without branches)

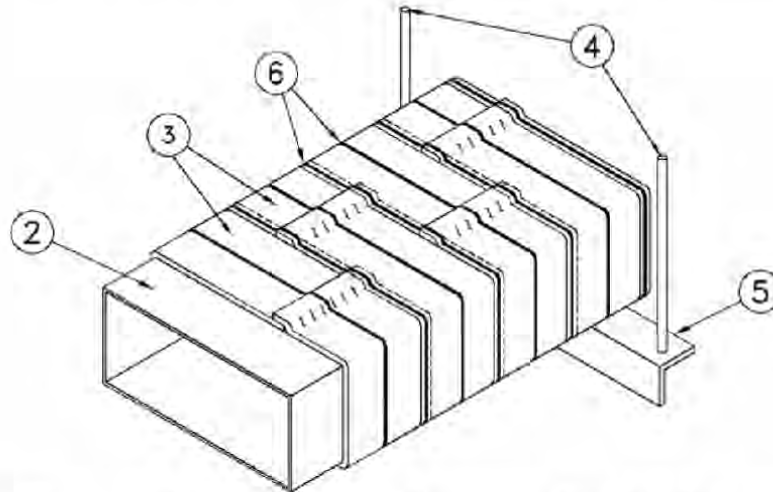

Maximum Size of Duct — 1.2 m² maximum area with no dimension exceeding 2.16 m. For ducts penetrating combustible floor/ceiling assemblies, maximum area 0.62 m² with no dimension exceeding 1.22 m.

Support Spacing — 1 500 mm maximum.

Duct Use Limitation — Duct is intended for use in pressurization situations or maximum negative pressure 300 Pa within duct.

1. **Masonry Wall or Floor** — Minimum depth or thickness as necessary for the grade of fire separation but not less than 115 mm. Normal-density or low-density concrete. Wall can also be constructed of nominal 190 mm thick concrete block laid up with mortar.
 - a) Or **Wall Assembly** — The fire-rated gypsum wallboard and steel or wood stud assembly shall be constructed of the materials and in the manner described in the individual Wall or Partition design in the ULC Fire Resistance directory.
 - b) Or **Floor/Ceiling Assembly** — The fire-rated combustible floor/ceiling assembly shall be constructed of the materials and in the manner described in the individual Floor-Ceiling design in the ULC Fire Resistance directory.
2. **Ventilation Air Duct** — Duct to be constructed in accordance with the requirements of the Standard for the Installation of Air Conditioning and Ventilation Systems, NFPA 90A. Minimum base metal thickness of 0.58 mm galvanized steel; maximum size of duct 600 mm by 2160 mm nominal (1.2 m² maximum area with no dimension exceeding 2.16 m). For ducts with any dimension greater than 1 000 mm, a 38 mm by 38 mm by 3 mm thick transverse stiffening angle, approximately 50 mm less than the maximum dimension, shall be screw attached 204 mm OC to the duct, 76 mm beyond the top surface of floor and both surfaces of wall.
3. **Duct Insulation** — (HNNZC) — 38 mm thick, Calcium-Magnesium-Silicate (CMS) duct wrap installed in accordance with the manufacturer's installation instructions and shall include the following features:
 - a) Copper-coated steel insulation pins (not shown), nominal 3 mm thick, minimum 102 mm long, shall be stud-welded to the bottom surface of steel duct on horizontal runs and on the widest surface on vertical runs of the steel duct at 305 mm OC maximum. For ducts less than 610 mm in width, no insulation pins are required.
 - b) The performance rating of the duct assembly penetrating a masonry floor or gypsum wall assembly is dependent on the number of layers of duct wrap. The Stability, Integrity and Insulation Rating of a wrapped duct penetrating a combustible floor/ceiling assembly is maximum 1 h, independent of the number of layers of wrap. The Duct Wrap material is installed using one of the options described below:

Assembly No. FRD 3
2-Hour Fire Resistance Rating (Duct A)
(Ratings applicable for Ventilation Ducts installed with or without branches)

OPTION A

- (i) For 2 h rating, one layer of duct wrap shall be installed around the duct with a perimeter and longitudinal overlap of minimum 76 mm. All joints shall be staggered minimum 267 mm. All cut edges to be taped with pressure sensitive aluminum foil, 76 mm wide. For ducts with any dimension greater than 39 in.(991 mm), a second layer of duct wrap shall abut the firestop and extend min 12 in. (305 mm) above and below floor slab or both surfaces of wall.
- (ii) The layer of blanket is locked into place over the insulation pins with 25 mm by 25 mm galvanized steel speed clips. Banding material (Item 6), 13 mm wide and minimum 0.3 mm thick, shall be installed with a tensioning tool and spaced at maximum 267 mm OC.

THERMAL CERAMICS INC — FireMaster Fast Wrap XL, Pyroscat Duct Wrap XL

- 4 & 5. **Hanger System** — Trapeze support hangers shall be used and spaced a maximum of 1500 mm OC. Hanger rods or straps shall be anchored with steel drop in or wedge expansion type masonry anchors embedded to the depth required by the anchor manufacturer. No additional protection is required for hangers and supports meeting the requirements of the table below.

Hanger Cross Section	Maximum Perimeter of Duct, (mm)	Trapeze Support
25 mm by 1.519 mm strap	2540	
6.4 mm threaded rod	1270	38 by 38 mm by 4.76 mm angle
9.5 mm threaded rod	3810	38 by 38 mm by 4.76 mm angle
12.7 mm threaded rod	5540	50 by 50 mm by 6.4 mm angle

As an option, the cradle assembly can be encased within the duct (cocoon wrap) during the installation of duct wrap (Item 3). To encase the cradle support, the duct wrap is slit maximum 152 mm to allow for the threaded rod. A generous application of ULC labeled firestop caulk (Item 9) is applied along the seam. The seam is taped over with minimum 76 mm wide aluminum tape. Additional material is installed such that a crown of minimum 13 mm is formed around the circumference of the threaded rod. When the overlap wrap method (Item 3, Option A) is used, the adjacent duct wrap to the threaded rod must be installed with enough overlap to cover the seam. If the butted joint method (Item 3, Option B) is used, the duct wrap collar must be installed to cover the seam.

6. **Steel Band** — Nominal 13 mm wide, 0.3 mm thick, made of stainless steel installed on wrapped duct with tensioning tool.

Firestop System Installation



2102 Old Savannah Rd, Augusta, GA
www.morganthermalceramics.com

Technical Support:
(706) 796-4306
firemaster@thermalceramics.com

Reprinted from the ULC Online Directories with permission from Underwriters Laboratories of Canada Inc. Created or Modified October 19, 2011



FRD 3
Page 2 of 4

Assembly No. FRD 3
2-Hour Fire Resistance Rating (Duct A)
(Ratings applicable for Ventilation Ducts installed with or without branches)

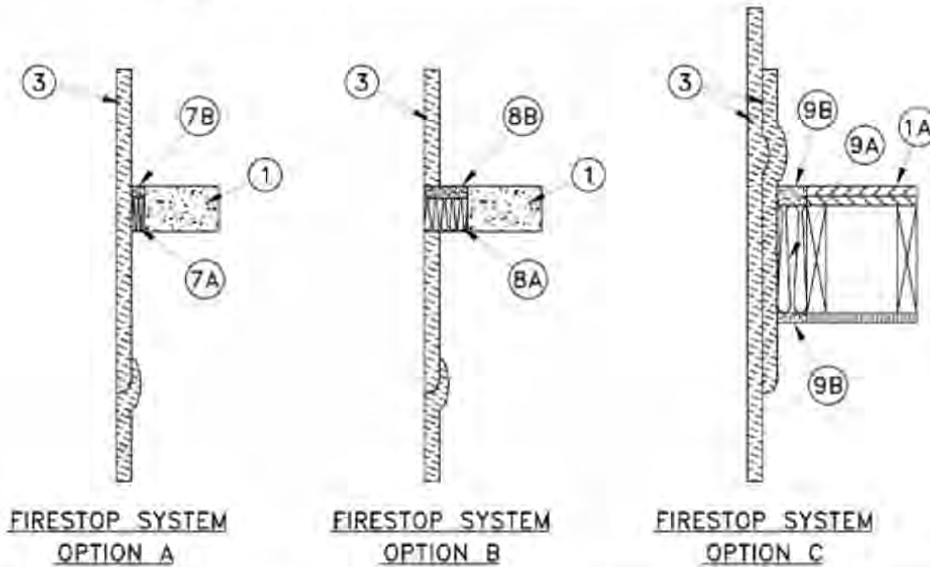

The duct shall be installed within the opening such that the annular space between the wrapped duct (for Firestop Option A), or steel duct (for Firestop Option B), and the edges of the opening is maximum 76 mm. For installations in gypsum wallboard assemblies, the opening to accommodate the duct shall be framed on all sides using lengths of stud installed between vertical studs and secured to the vertical studs.

For installations in combustible floor/ceiling assemblies, only Firestop Option C shall be used. The maximum and minimum annular spaces shall be 82 and 22 mm respectively. The opening to accommodate the duct shall be framed on all sides using lengths of nominal 38 mm by minimum 240 mm wood joists.

Option A – Firestop System Installation through Non-Combustible Floor or Combustible or Non-Combustible Wall Opening

7. a). **Firestop Insulation** — (HNNZC) — Unfaced duct insulation or ULC labelled mineral wool insulation with minimum 64 kg/m³ density compressed 50% minimum and installed into the opening to a minimum depth of 100 mm. Material to be recessed 6.4 mm from top surface of floor or both surfaces of wall to allow for the installation of sealant (Item 7b).
THERMAL CERAMICS INC — FireMaster FastWrap XL, Pyroscat Duct Wrap XL
- b). **Firestop System Component** — Sealant or caulk applied over insulation (Item 7a) to a minimum depth of 6.4 mm flush with top surface of floor or symmetrically to both surfaces of wall. Or self-leveling silicone sealant, for horizontal penetrations only, applied to a minimum depth of 6.4 mm flush with the top surface of floor slab.
SPECIFIED TECHNOLOGIES INC — SpecSeal 100 or SpecSeal LCI Sealant
HILTI CONSTRUCTION CHEMICALS, DIV OF HILTI INC — FS-ONE Sealant
TREMCO INC — Fyre-Sil, Fyre-Sil S/L, TREMstop Acrylic or TREMstop Intumescent Acrylic Sealant
RECTORSEAL — FS 900+ Sealant, FS 1900 Sealant
3M COMPANY — 3M Fire Barrier 2000 or 2000+, 3M Fire Barrier CP25WB+, 3M Fire Barrier 1003

Option B – Duct Wrap Terminated at Non-Combustible Floor or Combustible or Non-Combustible Wall Opening



2102 Old Savannah Rd, Augusta, GA
www.morganthermalceramics.com

Technical Support:
(706) 796-4306
firemaster@thermalceramics.com

Reprinted from the ULC Online Directories with permission from Underwriters Laboratories of Canada Inc.
Created or Modified October 19, 2011



FRD 3
Page 3 of 4

Assembly No. FRD 3

2-Hour Fire Resistance Rating (Duct A)

(Ratings applicable for Ventilation Ducts installed with or without branches)

8. a). **Firestop Insulation** — (HNNZC) — Unfaced duct insulation or ULC labelled mineral wool insulation with minimum 64 kg/m³ density compressed 50% minimum and installed into the opening to a minimum depth of 100 mm. For floor assemblies, the insulation is installed to full depth of floor and butted tightly against the duct wrap at the bottom surface of floor. The insulation is recessed 6.4 mm from the top surface of floor to allow for the installation of sealant (Item 8b). For wall assemblies, the insulation material is recessed 6.4 mm from both surfaces of wall to allow for the installation of sealant (Item 8b).

THERMAL CERAMICS INC — FireMaster Fast Wrap XL, Pyroscat Duct Wrap XL

- b). **Firestop System Component** — Sealant or caulk applied over insulation (Item 8a) to a minimum depth of 6.4 mm flush with top surface of floor or symmetrically to both surfaces of wall.

Self-levelling silicone sealant, for horizontal penetrations only, applied to a minimum depth of 6.4 mm flush with the top surface of floor slab. Additional sealant to be installed around the interface of duct wrap to ensure that no gap exists between sealant and duct wrap material.

SPECIFIED TECHNOLOGIES INC — SpecSeal 100 or SpecSeal LCI Sealant

HILTI CONSTRUCTION CHEMICALS, DIV OF HILTI INC — FS-ONE Sealant

TREMCO INC — Fyre-Sil, Fyre-Sil S/L, TREMstop Acrylic or TREMstop Intumescent Acrylic Sealant

RECTORSEAL — FS 900+ Sealant, FS 1900 Sealant

3M COMPANY — 3M Fire Barrier 2000 or 2000+, 3M Fire Barrier CP25WB+, 3M Fire Barrier 1003

Option C - One Hour Rating - 2 Layers Duct Wrap Continuous Through Combustible Floor/Ceiling Opening and Extending Minimum 305 mm Above and Below

9. a). **Firestop Insulation** — (HNNZC) — Unfaced duct insulation or ULC labelled mineral wool insulation with minimum 48 kg/m³ density compressed 50% minimum and installed into the opening to a minimum depth of 240 mm. Material to be recessed from surface of floor and of ceiling to accommodate required thickness of sealant (Item 9b).

THERMAL CERAMICS INC — FireMaster Fast Wrap XL, Pyroscat Duct Wrap XL

- b). **Firestop System Component** — (XHJZC) — Caulk applied over insulation (Item 9a) to a minimum depth of 32 mm flush with top surface of floor and to a minimum depth of 16 mm, flush with surface of ceiling.

SPECIFIED TECHNOLOGIES INC — SpecSeal 100 or SpecSeal LCI Sealant

HILTI CONSTRUCTION CHEMICALS, DIV OF HILTI INC — FS-ONE Sealant

TREMCO INC — Fyre-Sil, Fyre-Sil S/L, TREMstop Acrylic or TREMstop Intumescent Acrylic Sealant

RECTORSEAL — FS 900+ Sealant, FS 1900 Sealant

3M COMPANY — 3M Fire Barrier 2000 or 2000+, 3M Fire Barrier CP25WB+, 3M Fire Barrier 1003

10. **Firestop System Component** — Component (not shown) — (XHJZC) — Sealant applied in a generous bead along seam for the installation of duct wrap around cradle assembly (Item 5), in "cocoon wrap" applications if cradle penetrates the wrap. Additional material to be applied to form a crown of minimum 13 mm around the circumference of the threaded rod.

SPECIFIED TECHNOLOGIES INC — SpecSeal 100 or SpecSeal LCI Sealant

HILTI CONSTRUCTION CHEMICALS, DIV OF HILTI INC — FS-ONE Sealant

TREMCO INC — Fyre-Sil, Fyre-Sil S/L, TREMstop Acrylic or TREMstop Intumescent Acrylic Sealant

RECTORSEAL — FS 900+ Sealant, FS 1900 Sealant

3M COMPANY — 3M Fire Barrier 2000 or 2000+, 3M Fire Barrier CP25WB+, 3M Fire Barrier 1003

Copyright © 2013 Underwriters Laboratories of Canada Inc



2102 Old Savannah Rd, Augusta, GA

www.morganthermalceramics.com

Technical Support:
(706) 796-4306

firemaster@thermalceramics.com

Reprinted from the ULC Online Directories with permission from Underwriters Laboratories of Canada Inc.

Created or Modified October 19, 2011



FRD 3
Page 4 of 4

Assembly No. HNLJ,V-2
3-Hour Rating; Duct A; Ventilation Duct With or Without Branches

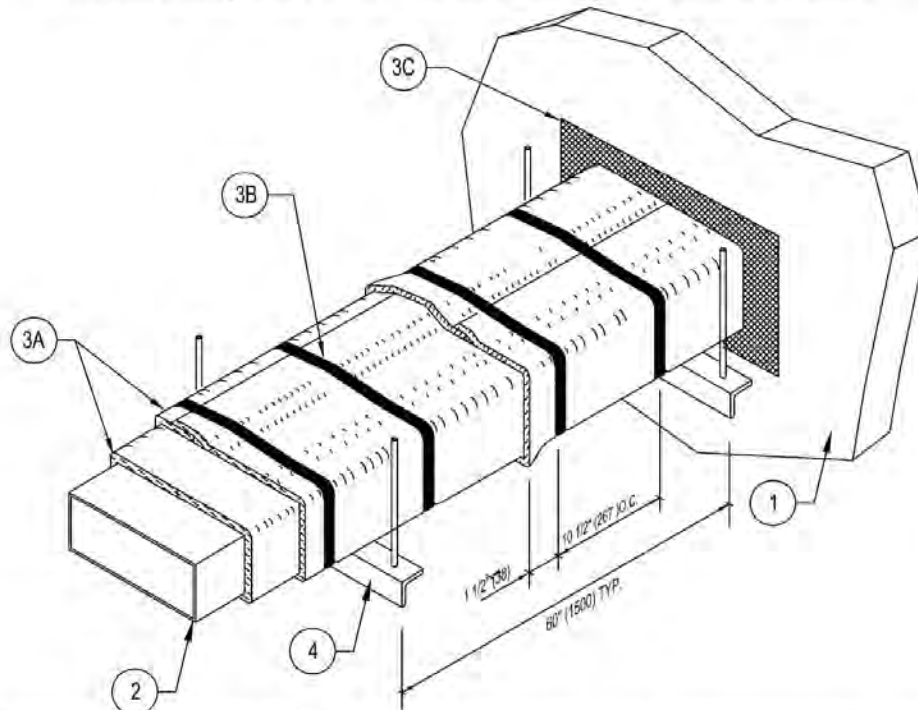

1. **Floor or Wall Assembly** — Floor or Wall Assembly — Min 4-1/2 in. (114 mm) thick reinforced lightweight or normal weight (100-150 pcf or 1600-2400 kg/m³) concrete floor or min 4-3/4 in. (121 mm) thick reinforced lightweight or normal weight concrete wall. Wall may also be constructed of any UL Classified Concrete Blocks. See **Concrete Blocks (CAZT)** category in the Fire Resistance Directory for Mfgs.
2. **Steel Air Duct** — Min 0.028 in. (No. 22 gauge or 0.71 mm) thick steel duct having a max perimeter dimension of 216 in. (5.49 m) and a max individual dimension of 84 in. (2.13 m). Duct sections shall be assembled using bolted flanges or SMACNA approved Transverse Joint Reinforcements. Duct to be rigidly supported in accordance with SMACNA requirements and as specified in Item 4.
3. **Fire Resistive System** — The fire resistive system shall consist of the following:
 - A. **Duct Wrap Materials* — Batts and Blankets*** — Nom 1-1/2 in. (38 mm) thick, 6 pcf (96 kg/m³) blanket totally encapsulated within foil-scrim facers. The steel duct shall be wrapped with two layers of duct wrap installed with tightly butted transverse and longitudinal joints on the first layer and with 3 in. (76 mm) transverse and longitudinal overlaps on the second layer in accordance with the manufacturer's installation instructions. The first and second layer joints shall be staggered a min of 10-1/2 in. (267 mm). All cut edges shall be sealed with 3 in. (76 mm) wide pressure sensitive aluminum foil tape.
THERMAL CERAMICS INC — FireMaster FastWrap XL and FastWrap+ or Pyroscat Duct Wrap XL
 - A1. **Collars** — Fabricated from Batts and Blankets* - (Not Shown) — Required when Item A is installed with transverse butt joints. Nom 1-1/2 in. (38 mm) thick, 6 pcf (96 kg/m³), 8 in. (203 mm) wide blanket totally encapsulated within foil-scrim facers. The butt joints shall be wrapped using a collar. The butt joint shall be located nom 4 in. (102 mm) from the edge of the collar. The collar shall be installed with 3 in. (76 mm) longitudinal overlaps. All cut edges and ends shall be sealed with 3 in. (76 mm) wide pressure sensitive aluminum foil tape.
THERMAL CERAMICS INC — FireMaster FastWrap XL and FastWrap+ or Pyroscat Duct Wrap XL

Assembly No. HNLJ.V-2

3-Hour Rating; Duct A; Ventilation Duct With or Without Branches

- B. **Steel Banding Straps** — Min 1/2 in. (13 mm) wide by 0.015 in. (0.38 mm) thick stainless or carbon steel banding straps used in conjunction with min 1 in. (25 mm) long stainless steel crimp clips. Banding straps spaced a max 12 in. (305 mm) OC and 1-1/2 in. (38 mm) from edges of collars.
- C. **Firestop System** — When the ventilation duct passes through a fire rated wall or floor assembly, the through openings shall be firestopped in accordance with System No. C-AJ-7014. See Through-Penetration Firestop Systems in Vol. 2 of the Fire Resistance Directory.
- 4. **Hanger System** — Trapeze support hangers shall be used and spaced a maximum of 60 in. (1500 mm) OC. Hanger rods or straps shall be anchored with steel drop in or wedge expansion type masonry anchors embedded to the depth required by the anchor manufacturer. No additional protection is required for hangers and supports meeting the requirements of the table below.

Hanger Cross Section	Maximum Perimeter of Duct, in. (m)	Trapeze Support
1 in. by 16 ga strap	100 (2.54)	
1/4 in. (6 mm) threaded rod	50 (1.27)	1-1/2 by 1-1/2 by 3/16 in. (38 by 38 by 4.8 mm) angle
3/8 in. (10 mm) threaded rod	150 (3.81)	1-1/2 by 1-1/2 by 3/16 in. (38 by 38 by 4.8 mm) angle
1/2 in. (13 mm) threaded rod	218 (5.54)	2 by 2 by 1/4 in. (51 by 51 by 6 mm) angle

*Bearing the UL Classification Mark



Assembly No. HNLJ.V-29
1-Hour Rating; Duct A;

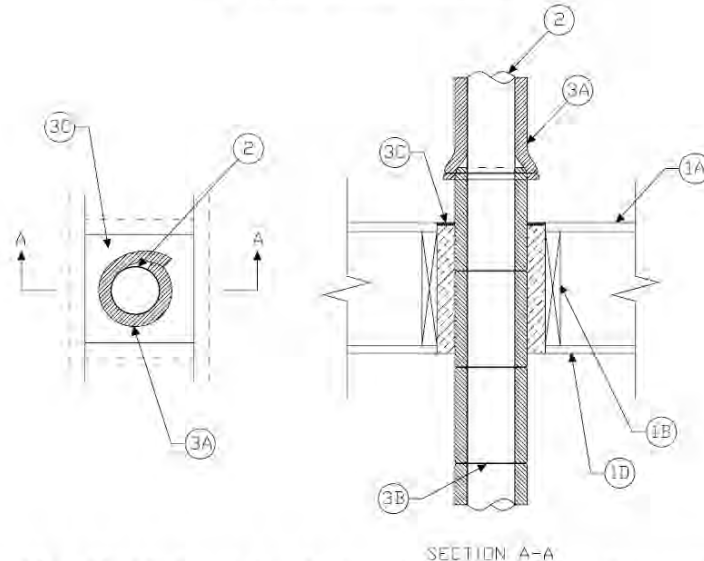

1. **Floor-Ceiling Assembly** — The 1 hr fire-rated solid or trussed lumber joist floor-ceiling assembly shall be constructed of the materials and in the manner specified in the individual L500 Series Floor-Ceiling Designs in the UL Fire Resistance Directory. The general construction details of the floor-ceiling assembly are summarized below:
 - A. **Flooring System** — Lumber or plywood subfloor with finish floor of lumber, plywood or **Floor Topping Mixture*** as specified in the individual Floor-Ceiling Design. Max area of floor opening is 81 in.2 (0.052 m²) with a max dimension of 10 in. (254 mm).
 - B. **Wood Joists** — Nom 10 in. (254 mm) deep (or deeper) lumber, steel or combination lumber and steel joists, trusses or **Structural Wood Members*** with bridging as required and with ends firestopped. Additional framing members installed to form a square enclosure around the perimeter of the opening in the floor and ceiling.
 - C. **Furring Channels** — (Where required - not shown) - Resilient galv steel furring installed perpendicular to wood joists between gypsum board and wood joists as specified in the individual Floor-Ceiling Design. Furring channels spaced max 24 in. (610 mm) OC. If furring channels are used within the assembly, additional furring channels to be installed around the periphery of the opening.
 - D. **Gypsum Board*** — Nom 4 ft (1.2 m) wide by 5/8 in. (15.9 mm) thick as specified in the individual Floor-Ceiling Design. Gypsum board secured to wood joists or furring channels as specified in the individual Floor-Ceiling Design. Max area of ceiling opening is 81 in.2 (0.052 m²) with a max dimension of 10 in. (254 mm).
2. **Steel Air Duct** — Max 4 in. (102 mm) diam by min 0.0157 in. (No. 30 gauge or 0.40 mm) thick galv steel air duct to be centered within the firestop system. Max one steel air duct to be installed within opening. Steel duct to be rigidly supported on both sides of floor-ceiling assembly.
3. **Fire Resistive System** — The fire resistive system shall consist of the following:
 - A. **Duct Wrap Materials* — Batts and Blankets*** — Nom 1 in. (25 mm) thick, 6 pcf (96 kg/m³) with or without foil-scrim facers. The steel duct shall be wrapped with one layer of duct wrap installed with 2 in. (50 mm) transverse and longitudinal overlaps in accordance with the manufacturer's installation instructions. Alternatively, joints may be tightly butted with 1 in. (25 mm) compression or overlapped 1 in. (25 mm). **THERMAL CERAMICS INC** — FireMaster DryerWrap and FastWrap XL or Pyroscat Duct Wrap XL
 - B. **Steel Tie Wire** — Min No. 14 Gauge (0.080 in. or 2.0 mm) galvanized steel wire formed into a loop on one end, with the other end passed through the loop, pulled hand tight and bent over. Tie wires spaced a max 8 in. (203 mm) OC.
 - C. **Firestop System** — When the ventilation duct passes through a fire rated floor assembly, the through openings shall be firestopped in accordance with System No. F-C-7055.

*Bearing the UL Classification Mark

Assembly No. FRD 28
1-Hour Fire Resistance Rating (Duct A)

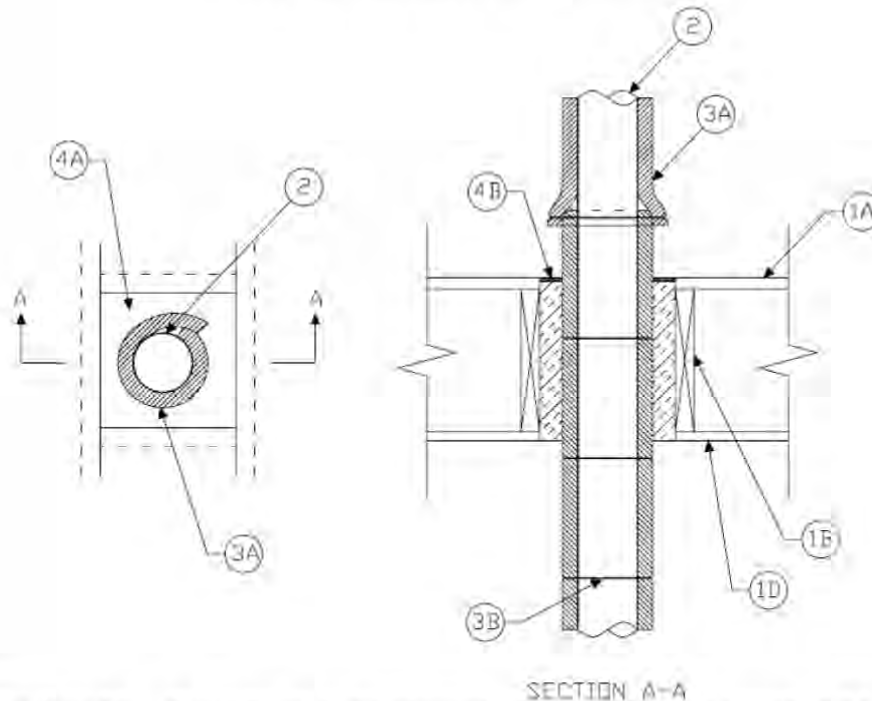

1. **Floor-Ceiling Assembly** — The 1 h fire-rated solid or trussed lumber joist floor-ceiling assembly shall be constructed of the materials and in the manner specified in the individual M500 Series Floor-Ceiling Designs in the ULC Fire Resistance Directory. The general construction details of the floor-ceiling assembly are summarized below:
 - A. **Flooring System** — Lumber or plywood subfloor with finish floor of lumber, plywood or Floor Topping Mixture as specified in the individual Floor-Ceiling Design. Maximum area of floor opening is 0.052 m² with a maximum dimension of 254 mm.
 - B. **Wood Joists** — Nominal 254 mm deep (235 mm minimum) lumber, steel or combination lumber and steel joists, trusses or Structural Wood Members with bridging as required and with ends firestopped. Additional framing members installed to form a square enclosure around the perimeter of the opening in the floor and ceiling.
 - C. **Furring Channels** — (Where Required - Not Shown) - Resilient galvanized steel furring channels installed perpendicular to wood joists between gypsum board and wood joists as specified in the individual Floor-Ceiling Design. Furring channels spaced maximum 610 mm OC. If furring channels are used in the assembly, additional furring channels to be installed around the periphery of the opening.
 - D. **Gypsum Board** — Nominal 1220 mm wide by 15.9 mm thick as specified in the individual Floor-Ceiling Design. Gypsum board secured to wood joists or furring channels as specified in the individual Floor-Ceiling Design. Maximum area of ceiling opening is 0.052 m² with a maximum dimension of 254 mm.
2. **Steel Air Duct** — Maximum 102 mm diameter by minimum 0.40 mm thick (30 GA) galvanized steel air duct to be centered within the firestop system. Maximum one steel air duct to be installed within opening. Steel duct to be rigidly supported on both sides of floor-ceiling assembly.
3. **Fire Resistive System** — The fire resistive system shall consist of the following:
 - A. ***Duct Insulation** — (HNNZC) — Minimum 25 mm thick, Calcium-Magnesium-Silicate (CMS) duct wrap, 96 kg/m³ with or without foil-scrim facers installed in accordance with the manufacturer's installation instructions. The

Assembly No. FRD 28
1-Hour Fire Resistance Rating (Duct A)

steel duct shall be wrapped with one layer of duct wrap installed with 50 mm transverse and longitudinal overlaps. Alternatively, joints may be tightly butted with 25 mm compression or overlapped 25 mm. **THERMAL CERAMICS INC** — FireMaster DryerWrap and FastWrap XL or Pyroscat Duct Wrap XL

- B. **Steel Tie Wire** — Minimum 2.0 mm diameter (14 GA) galvanized steel wire formed into a loop on one end, with the other end passed through the loop, pulled hand tight and bent over. Tie wires spaced maximum 203 mm OC.

Firestop System Installation

The wrapped duct shall be installed such that the annular space between the duct and edges of the opening is maximum 38 mm. Duct shall be supported on both sides of floor.

- 4. ***Firestop System Components** — (XHJZC) — Installed in accordance with manufacturer's instructions and as described herein:
 - A. **Firestop Insulation** — Minimum 257 mm thickness of unfaced duct wrap material or minimum 48 kg/m³ mineral wool batt insulation firmly packed into opening as a permanent form. Insulation to be recessed from top surface of floor as required to accommodate the required thickness of sealant.
 - B. **Firestop System Component** — Minimum 6.4 mm thickness of sealant material, applied within the annulus, flush with top surface of floor.
 - 3M COMPANY — 3M Fire Barrier Sealant CP-25WB+
 - HILTI CONSTRUCTION CHEMICALS, DIV OF HILTI INC — FS-ONE Sealant
 - SPECIFIED TECHNOLOGIES INC — SpecSeal 100 or SpecSeal LCI Sealant
 - THERMAL CERAMICS INC — FireMaster Putty
 - TREMCO INC — Fyre-Sil, Fyre-Sil S/L, TREMstop Acrylic or TREMstop Intumescent Acrylic Sealant
 - W R GRACE & CO - CONN — FS 900+ Sealant, FS 1900 Sealant

*Bearing the ULC Listing Mark

Copyright © 2013 Underwriters Laboratories of Canada Inc



2102 Old Savannah Rd, Augusta, GA
www.morganthermalceramics.com

Technical Support:
(706) 796-4306
firemaster@thermalceramics.com

Reprinted from the ULC Online Directories with
permission from Underwriters Laboratories of Canada Inc.
Created or Modified December 14, 2012



FRD 28
Page 2 of 2

System No. C-AJ-7019

ANSI/UL1479 (ASTM E814)		CAN/ULC S115
F Rating - 1 Hr	T Rating - 1 Hr	FTH Rating - 1 Hr

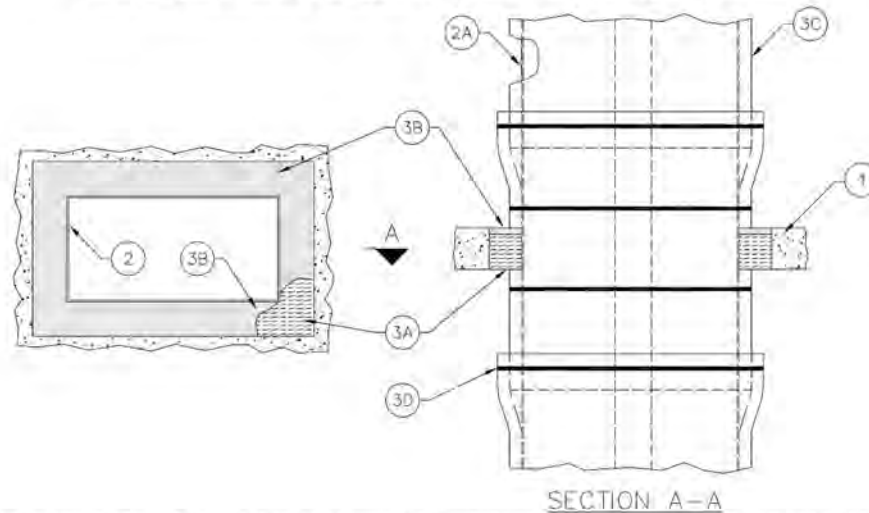

1. **Floor or Wall Assembly** — Min 4-1/2 in. (114 mm) thick reinforced normal weight (140-150 pcf or 2240-2400 kg/m³) concrete floor or min 4-3/4 in. (121 mm) thick reinforced normal weight concrete wall. Wall may also be constructed of any UL Classified **Concrete Blocks***. Max area of opening is 18.75 ft² (1.74 m²) with a max dimension of 90 in. (2.3 m). See **Concrete Blocks (CAZT)** category in the Fire Resistance Directory for Mfgs.
2. **Through-Penetrant** — One steel duct to be installed within the firestop system with an annular space of 3 in. (76 mm). Duct to be rigidly supported on both sides of floor or wall assembly. The following types of through-penetrants may be used:
 - A. **Steel Air Duct** — Min 26 gauge (0.021 in. or 0.53 mm) thick carbon steel duct having a max perimeter dimension of 216 in. (5.5 m) and a max individual dimension of 84 in. (2.13 m). Ducts with any dimension greater than 39 in. (0.99 in.), shall be provided with intermediate reinforcement in accordance with SMACNA HVAC Duct Construction Standards. Reinforcement to consist of min 1-1/2 in. (38 mm) by 1-1/2 in. (38 mm) by 1/8 in. (3 mm) thick transverse stiffening angles, approximately 2 in. (51 mm) less in length than the max dimension, screw attached 8 in. (203 mm) OC to the duct 3 in. (76 mm) beyond the top surface of the floor and both surfaces of the wall.
3. **Firestop System** — The firestop system shall consist of the following:
 - A. **Packing Material** — Min 4 in. (102 mm) thickness of unfaced scrap duct wrap material or min 3 pcf (48 kg/m³) mineral wool batt insulation firmly packed into opening as a permanent form between the bare steel duct and the periphery of the opening. Packing material to be recessed from the top surface of the floor or both surfaces of wall as required to accommodate the required thickness of fill material.
 - B. **Fill, Void or Cavity Material* — Sealant** — Min 1/2 in. (13 mm) thickness of fill material applied within the annulus, flush with top surface of floor or both surfaces of wall.
TREMCO INC — Fyre-Sil Sealant or Fyre-Sil S/L Sealant (for floor assemblies only)
 - C. **Duct Wrap Materials*** — Nom 1-1/2 in. (38 mm) thick, 6 pcf (96 kg/m³) ceramic blanket totally encapsulated within foil-scrim facers. The steel duct shall be wrapped with one layer of duct wrap installed in accordance with the manufacturer's installation instructions, maintaining min 3 in. (76 mm) transverse and longitudinal overlaps. The duct wrap shall be tightly butted to the floor or wall on both sides of the assembly. All cut edges and ends shall be sealed with 3 in. (76 mm) wide pressure sensitive aluminum foil tape.
THERMAL CERAMICS INC — FireMaster FastWrap XL and FastWrap+ or Pyroscat Duct Wrap XL
 - D. **Steel Banding Straps** — Min 1/2 in. (13 mm) wide by 0.015 in. (0.38 mm) thick carbon steel banding straps used in conjunction with min 1 in. (25 mm) long stainless steel crimp clips. Banding straps spaced a max 12 in. (305 mm) OC and 1-1/2 in. (38 mm) from transverse joints of duct wrap.

*Bearing the UL Classification Mark



2102 Old Savannah Road, Augusta, GA
www.morganthermalceramics.com
Technical Support:
(706) 796-4306
firemaster@thermalceramics.com

Reproduced Courtesy of Underwriters Laboratories Inc.
Created or Modified August 9, 2011



C-AJ-7019
Page 1 of 1

System No. C-AJ-7095

ANSI/UL1479 (ASTM E814)		CAN/ULC S115
F Rating - 2 Hr	T Rating - 2 Hr	FTH Rating - 2 Hr

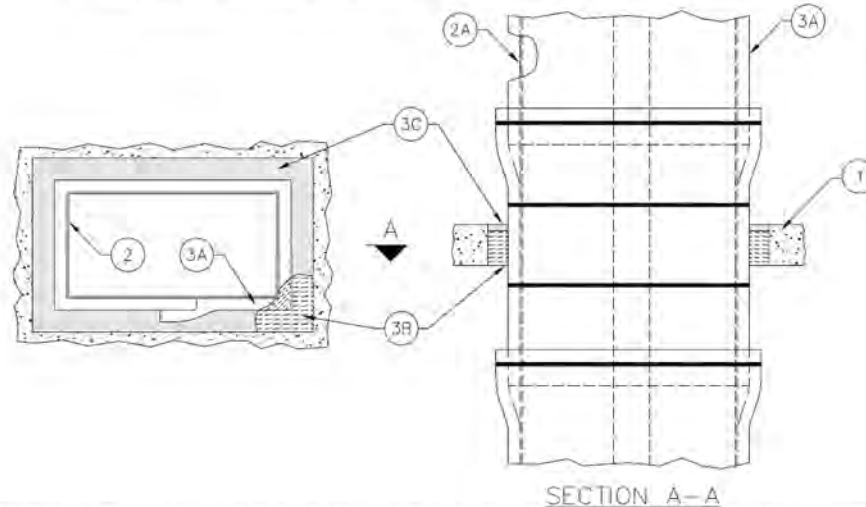

1. **Floor or Wall Assembly** — Min 4-1/2 in. (114 mm) thick reinforced normal weight (140-150 pcf or 2240-2400 kg/m³) concrete floor or min 4-3/4 in. (121 mm) thick reinforced normal weight concrete wall. Wall may also be constructed of any UL Classified **Concrete Blocks***. Max area of opening is 912 in² (0.59 m²) with max dimension of 48 in. (1.22 m). See **Concrete Blocks (CAZT)** category in the Fire Resistance Directory for Mfgs.
2. **Through-Penetrant** — One steel duct to be installed within the firestop system. Duct to rigidly supported on both sides of floor or wall assembly. The following types of through-penetrants may be used:
 - A. **Steel Air Duct** — Min 0.030 in. (0.76 mm or 22 gauge) thick steel duct having a max width to height ratio of 4 to 1 with max individual dimension of 39 in (0.99 m) and constructed in accordance with SMACNA HVAC Duct Construction standards. The sections shall be assembled using bolted flanges or SMACNA approved Transverse Joint Reinforcements. Reinforcement to consist of min 1-1/2 by 1-1/2 by 1/8 in. (38 by 38 by 3.2 mm) thick transverse stiffening angles, approximately 2 in. (51 mm) less in length than the max dimension, screw attached 8 in. (203 mm) OC to the duct 3 in. (76 mm) beyond the top surface of the floor and both surfaces of the wall.
3. **Firestop System** — The firestop system shall consist of the following:
 - A. **Duct Wrap Materials*** — Nom 1-1/2 in. (38 mm) thick, 6 pcf (96 kg/m³), ceramic blanket totally encapsulated within foil-scrim facers. The steel duct shall be wrapped with one layer of duct wrap installed in accordance with the Ventilation Assembly No. V-19. See Ventilation Duct Assemblies in Vol. 2 of the Fire Resistance Directory. A nom annular space of 3 in. (76 mm) is required between the insulated duct and the periphery of the opening.
THERMAL CERAMICS INC — FireMaster FastWrap XL and FastWrap+ or Pyroscat Duct Wrap XL
 - B. **Packing Material** — Min 4 in. (102 mm) thickness of unfaced scrap duct wrap material or min 3 pcf mineral wool batt insulation firmly packed into opening as a permanent form. Packing material to be recessed from the top surface of the floor or both surfaces of wall as required to accommodate the required thickness of fill material.
 - C. **Fill, Void or Cavity Material* — Sealant** — Min 1/4 in. (6 mm) thickness of fill material applied within the annulus, flush with top surface of floor or with both surfaces of wall.
SPECIFIED TECHNOLOGIES INC — Pensil 300 Sealant or SpecSeal Series SIL300 Sealant
HILTI CONSTRUCTION CHEMICALS, DIV OF HILTI INC — FS ONE Sealant
RECTORSEAL — 835+ Sealant
TREMCO INC — Fyre-Sil Sealant or Fyre-Sil S/L Sealant (for floor assemblies only)

*Bearing the UL Classification Mark

System No. W-J-7086

ANSI/UL1479 (ASTM E814)

F Rating - 2 Hr	T Rating - 2 Hr	L Rating At Ambient - Less Than 1 CFM/sq ft
		L Rating At 400 F - Less Than 1 CFM/sq ft

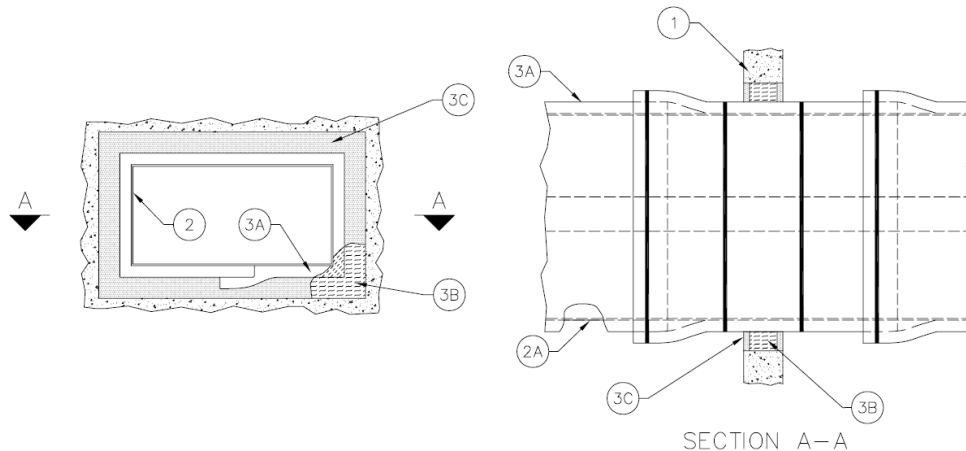

1. **Floor or Wall Assembly** — Min 6 in. (152 mm) thick reinforced lightweight or normal weight (100-150 pcf or 1600-2400 kg/m³) concrete. Wall may also be constructed of any UL Classified **Concrete Blocks***. Max area of opening is 78 ft.2 (7.3 m²) with a max dimension of 107 in. (272 cm). See **Concrete Blocks (CAZT)** category in the Fire Resistance Directory for Mfgs.
2. **Steel Air Duct** — One steel duct to be installed within the firestop system. Duct to be rigidly supported on both sides of wall assembly. Min 26 gauge (0.5 mm) galv steel duct having a max perimeter dimension of 400 in. (0.274 m) and a max individual dimension of 100 in. (762 mm).
3. **Firestop System** — The firestop system shall consist of the following:
 - A. **Duct Wrap Materials*** — Nom 1-1/2 in. (38 mm) thick blanket totally encapsulated within foil-scrim facers. The steel air duct shall be wrapped with one layer of duct wrap installed in accordance with Ventilation Assembly Nos. V-1 or V-19. See Ventilation Duct Assemblies in Vol. 2 of the Fire Resistance Directory. When steel angles (Item 3D) are used, the edges of the duct wrap material are to abut the protruding leg of the angle and the tight seam is to be covered with an additional 6 in. (152 mm) wide "collar" of duct wrap. The annular space between the insulated duct and the periphery of the opening shall be min 0 in. (0 mm, point contact) to max 2 in. (51 mm).
THERMAL CERAMICS INC — FireMaster FastWrap XL and FastWrap+ or Pyroscat Duct Wrap XL
 - B. **Packing Material** — Min 4-3/4 in. (121 mm) thickness of unfaced scrap duct wrap material or min 4 pcf (64 kg/m³) mineral wool batt insulation firmly packed into the opening as a permanent form. Packing material to be recessed from both surfaces of wall as required to accommodate the required thickness of fill material (Item 4B). When steel angles (Item 3D) are used, packing material shall be firmly packed into opening as a permanent form between the bare steel duct and the periphery of the opening.
 - C. **Fill, Void or Cavity Material***— **Sealant** — Min 5/8 in. (16 mm) thickness of fill material applied within annulus, flush with both surfaces of wall assembly. A min 1/4 in. (6 mm) diam bead of sealant shall be applied at the concrete wall/insulated duct interface on both surfaces of wall assembly.
SPECIFIED TECHNOLOGIES INC — SpecSeal 100, LC150, LCI Sealant, or Pensil 300 Silicone Sealant
 - D. **Retaining Angles** — (Not Shown) — When dimensions of duct exceed 84 by 84 in. (213 by 213 cm), min No. 16 gauge (0.059 in. (1.5 mm)) galv steel angles sized to lap steel duct a min of 2 in. (51 mm) and to lap wall surfaces a min of 1 in. (25 mm). Angles attached to steel duct on both sides of wall within 1 in. (25 mm) of wall with min No. 10 by 1/2 in. (13 mm) long steel sheet metal screws or welds located a max of 1 in. (25 mm) from each end of steel duct and spaced a max of 6 in. (152 mm) OC.

*Bearing the UL Classification Mark

System No. W-L-7145

ANSI/UL1479 (ASTM E814)	
F- and T- Rating – 1 and 2 Hr (See Item 1)	L Rating At Ambient - Less Than 1 CFM/sq ft
	L Rating At 400 F - Less Than 1 CFM/sq ft

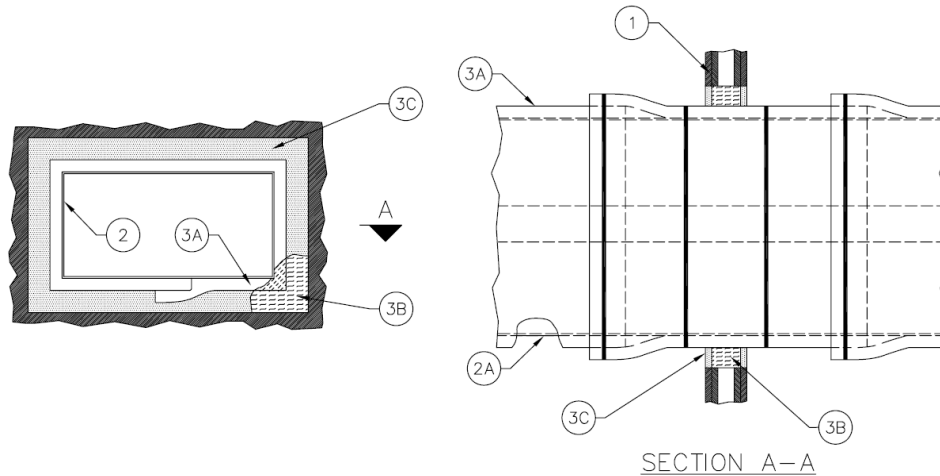

1. **Wall Assembly** — The 1 or 2 hr fire-rated gypsum board/stud wall assembly shall be constructed of the materials and in the manner specified in the individual U400 or V400 Series Wall and Partition Design in the Fire Resistance Directory and shall include the following construction features:
 - A. **Studs** — Wall framing shall consist of min 3-1/2 in. (89 mm) wide channel shaped steel studs spaced max 24 in. (610 mm) OC. Additional framing members shall be installed in stud cavity to form a rectangular box around the penetrant.
 - B. **Gypsum Board*** — 5/8 in. (16 mm) thick with square or tapered edges. The gypsum board type, thickness, number of layers, fastener type and sheet orientation shall be as specified in the individual U400 or V400 Wall and Partition Design. Max area of opening is 78 ft.2 (7.3 m²) with a max dimension of 107 in. (272 cm).

The hourly F and T Ratings of the firestop system are equal to the hourly fire rating of the wall assembly in which it is installed.
2. **Steel Air Duct** — One steel duct to be installed within the firestop system. Duct to be rigidly supported on both sides of wall assembly. Min 26 gauge (0.5 mm) galv steel duct having a max perimeter dimension of 400 in. (0.274 m) and a max individual dimension of 100 in. (762 mm).
3. **Firestop System** — The firestop system shall consist of the following:
 - A. **Duct Wrap Materials*** — Nom 1-1/2 in. (38 mm) thick blanket totally encapsulated within foil-scrim facers. The steel air duct shall be wrapped with one layer of duct wrap installed in accordance with Ventilation Assembly Nos. V-1 or V-19. See Ventilation Duct Assemblies in Vol. 2 of the Fire Resistance Directory. When steel angles (Item 3D) are used, the edges of the duct wrap material are to abut the protruding leg of the angle and the tight seam is to be covered with an additional 6 in. (152 mm) wide "collar" of duct wrap. The annular space between the insulated duct and the periphery of the opening shall be min 0 in. (0 mm, point contact) to max 2 in. (51 mm).
THERMAL CERAMICS INC — FireMaster FastWrap XL and FastWrap+ or Pyroscat Duct Wrap XL
 - B. **Packing Material** — Min 3-1/2 in. (89 mm) and 4-3/4 in. (121 mm) thickness of unfaced scrap duct wrap material or min 4 pcf (64 kg/m³) mineral wool batt insulation firmly packed into the opening as a permanent form for 1 and 2 hr rated walls, respectively. Packing material to be recessed from both surfaces of wall as required to accommodate the required thickness of fill material (Item 4B).
 - C. **Fill, Void or Cavity Material*— Sealant** — Min 5/8 in. (16 mm) thickness of fill material applied within annulus, flush with both surfaces of wall assembly. A min 1/4 in. (6 mm) diam bead of sealant shall be applied at the gypsum board/insulated duct interface on both surfaces of wall assembly.
SPECIFIED TECHNOLOGIES INC — SpecSeal 100, LC150, LCI Sealant, or Pensil 300 Silicone Sealant

System No. W-L-7145

D. **Retaining Angles** — (Not Shown) — When dimensions of duct exceed 84 by 84 in. (213 by 213 cm), min No. 16 gauge (0.059 in. or 1.5 mm thick) galv steel angles sized to lap steel duct a min of 2 in. (51 mm) and to lap wall surfaces a min of 1 in. (25 mm) shall be attached to steel duct. Angles attached to steel duct on both sides of wall within 1 in. (25 mm) of wall with min No. 10 by 1/2 in. (13 mm) long steel sheet metal screws or welds located a max of 1 in. (25 mm) from each end of steel duct and spaced a max of 6 in. (152 mm) OC.

*Bearing the UL Classification Mark



2102 Old Savannah Road, Augusta, GA
www.morganthermalceramics.com
Technical Support:
(706) 796-4306
firemaster@thermalceramics.com

Reproduced Courtesy of Underwriters Laboratories Inc.
Created or Modified July 20, 2011



W-L-7145
Page 2 of 2

Additional Technical Support

- Visit our website: www.morganthermalceramics.com
- Mail your comments to: PO Box 923 • Augusta, GA • 30903
- Contact us directly:
 - T: 1.706.796.4306
 - Email: mike.johnson@morganplc.com

Additional Specification Documents

- Visit www.sweets.com; search Thermal Ceramics
- Visit www.arcat.com; search Thermal Ceramics

ICC-ES Reports can be downloaded at:

- FireMaster http://www.icc-es.org/reports/pdf_files/ICC-ES/ESR-2213.pdf
- Pyroscat http://www.icc-es.org/reports/pdf_files/ICC-ES/ESR-2832.pdf

Additional UL Listings can be downloaded at:

- www.ul.com

Complete Solutions
Grease and HVAC Duct
Fire Protection

